

REGGO[®]



**Cryogenic &
Industrial Gas
Equipment**

O₂

NITROGEN

CO₂

NITROGEN

LNG

Helium

Hydrogen

Oxygen

CO₂

CO₂

Argon

Foreword

This catalog briefly describes the Rego® Industrial Gas and Cryogenic Equipment available from the Cryo-Flow division of RegO. As a result of condensing information in this catalog, some highly technical and special application material has been omitted. Proper application, installation and maintenance of the product is essential. Buyers should obtain further information if there are any doubts or questions. All information contained in this catalog is subject to change by RegO without notice. Additional product information is available from RegO or authorized product distributors. Illustrations and drawings of individual products are representative of “product groups” and all products within a product group are similar in construction.

Warning

Never use any product on oxygen service if another gas has been previously used on the product. All RegO® Products are mechanical devices that will eventually become inoperative due to wear, corrosion and aging of components made of materials such as rubber. The environment and conditions of use will determine the safe service life of these products. Periodic inspection and maintenance are essential to avoid serious injury and property damage.

Many RegO® products are manufactured for storage, transport, transfer and use of toxic flammable and dangerous liquids and gases. Such substances should be handled by experienced and trained personnel only, using accepted governmental and industrial safety procedures.

Materials

Rego Cryo-Flow Products Division may make suggestions for a material to use with a specific media. These suggestions will be based on technical compatibility resources through associations and manufacturers. Rego does not guarantee the material to be compatible with the specific media – this is the responsibility of the user. Users must test under their own operating conditions to determine the suitability of any material in a particular application.

Oxygen Service

Rego Cryo-Flow Products Division provides specified product cleaned in accordance with the intermediate level of ASTM G93 and CGA G-4.1 which assures removal of visible particles and combustible residues. System designers must verify the compatibility of the materials used in this product before installation and operation. Specifications of materials for oxygen service is the USER'S RESPONSIBILITY. If there is any doubt consult an expert.

Notice

Installation, usage and maintenance of all RegO® Products must be in compliance with all RegO® instructions as well as requirements and provisions of NFPA 51, CGA, ASME, DOT, ANSI and all applicable federal, state, provincial and local standards, codes, regulations and laws.

Inspection and maintenance on a periodic basis is essential and should be performed only by qualified personnel.

Be sure all instructions are read and understood before installation, operation and service.

Table of Contents

985B	9	2523HP-80A	39	B-00202X-12S4	54	B-000322-24S4	52
985D	9	2523HP-80B	39	B-00202X-12T4	54	B-000322-24T4	52
985E	9	2553AAC	6	B-00202X-16S4	54	B-000326-4T6	52
985F	9	2553AC	6	B-00202X-16T4	54	B-000326-6T6	52
1042	37	2553AC-80	38	B-0206LL-2T6	55	B-000326-8T6	52
1042-20	37	2554AAC	6	B-0206LL-3T6	55	B-000326-12T6	52
1043	36	2554AC	6	B-0206LL-4S6	55	B-000326-16T6	52
1045	37	2554AC-80	38	B-0206LL-4T6	55	B-000840-4S	65
1050-15	36	4285-9B	35	B-0206LL-6S6	55	B-000840-4T	65
1050-20	36	4286A580	34	B-0206LL-6T6	55	B-000840-6S	65
1050-40	36	4289-10	35	B-0206LL-8S6	55	B-000840-6T	65
1050-60	36	4289AG	34	B-0206LL-8T6	55	B-000840-8S	65
1050-80	36	4289G	34	B-206ULL-12S6	55	B-000840-8T	65
1075-20	36	4291A	34	B-206ULL-12T6	55	B-000840-12S	65
1075-30	36	4403W-P4	32	B-206ULL-16S6	55	B-000840-12T	65
1075-40	36	4403W-R4	32	B-206ULL-16T6	55	B-000840-16S	65
1075-50	36	4403W-S4	32	B-00222X-2T4	58	B-000840-16T	65
1075-60	36	4403W-T4	32	B-00222X-4S4	59	B-000846M-4S6	66
1225-1	37	4403W-U4	32	B-00222X-4T4	58	B-000846M-4T6	65
1225-3	37	4608-5	37	B-00222X-6S4	59	B-000846M-6S6	66
1227-1	37	5562C	9	B-00222X-6T4	58	B-000846M-8S6	66
1227-3	37	7160-80B	38	B-00222X-8S4	59	B-000846M-8T6	65
1227-9	37	7160V	8	B-00222X-8T4	58	B-000846M-12S6	66
1227-28	37	7160VL	8	B-00222X-12S4	59	B-000846M-12T6	65
1228-1	36	7161V	8	B-00222X-12T4	58	B-000846M-16S6	66
1228-2	36	7161VL	8	B-00222X-16S4	59	B-000846M-16T6	65
1228-4	36	9464RL-0	18	B-00222X-16T4	58	B-9472-80	39
1286	9	9464RL-1	18	B-00222X-20T4	58	B-9473-80	39
1682M	33	9464RL-2	18	B-00222X-24S4	59	B-9473M-80	39
1682M-80	39	9464RL-3	18	B-00222X-24T4	58	B-19434B235	26
1682MG	33	9500-80K	38	B-226BLL-12T6	59	B-19434B250	26
1682ML	33	9550-3-80	38	B-226BLL-16T6	59	B-19434B300	26
1682MLG	33	9550-4-80	38	B-226BLL-2T6	59	B-19434B350	26
1682MS	33	9550-80	38	B-0226LL-2T6	59	B-19434B375	26
1682MSG	33	9560-80	38	B-0226LL-3T6	59	BK8400-80AJ	38
1682Y-80	39	9560A	5	B-0226LL-4S6	59	BK8400-80BJ	38
1684M-80	39	9560ASE	5	B-0226LL-4T6	59	BK8400-80J	38
1684MHP-80	39	9560B	5	B-0226LL-6S6	59	BK8404S	11
1684Y-80	39	9560BSE	5	B-0226LL-6T6	59	BK8404ST	11
1686M-80	39	9560BSE-B	5	B-0226LL-8S6	59	BK8404T	11
1686MHP-80	39	9560C-80	38	B-0226LL-8T6	59	BK8406S	11
1686Y-80	39	9560CA	5	B-0226LL-8T6	59	BK8406T	11
1784-7SKA	27	9560CASE	5	B-226ULL-12S6	59	BK8408S	11
1784-7SKB	27	9560CB	5	B-226ULL-12T6	59	BK8408T	11
1784-7SKC	27	9560CBSE	5	B-226ULL-16S6	59	BK8508S	15
1784-80	27	9560CBSE-B	5	B-226ULL-16T6	59	BK8508T	15
1784A	29	9561CL	5	B-000302-4S4	49	BK8512S	15
1784B	29	9561CR	5	B-000302-4T4	49	BK8512T	15
1784C	29	9561CRL	5	B-000302-6S4	49	BK9400-80AJ	38
1784ST	27	9561L	5	B-000302-8S4	49	BK9400-80J	38
1786-7SKA	27	9561R	5	B-000302-12S4	49	BK9404AA	11
1786-7SKB	27	9561RL	5	B-000302-16S4	49	BK9404PT-F30	11
1786-7SKC	27	9563CL	5	B-000302-20S4	49	BK9404S	11
1786-80	27	9563CR	5	B-000302-20T4	49	BK9404ST	11
1786A	29	9563L	5	B-000302-24S4	49	BK9406S	11
1786B	29	9563R	5	B-000302-24T4	49	BK9406T	11
1786C	29	10663	9	B-000306-6T6	49	BK9408AA	11
1786ST	27	10664	9	B-000306-8T6	49	BK9408PT-F30	11
1786ST	27	15578	9	B-000306-12T6	49	BK9408S	11
1788-7SKA	27	B-000006-M	67	B-000306-16T6	49	BK9408T	11
1788-7SKB	27	B-000012-M	67	B-000310-20T	49	BK9410S*	11
1788-7SKC	27	B-000018-M	67	B-000310-24S	49	BK9412AA	11
1788A	29	B-000025-M	67	B-000310-24T	49	BK9412PT-F30	11
1788B	29	B-000031-M	67	B-000310-24S	49	BK9412S*	11
1788C	29	B-000038-M	67	B-000310-24T	49	BK9412T*	11
2118-2	37	B-000050-M	67	B-000310X-20T	49	BK9416PT-F30	11
2222-1	37	B-000062-M	67	B-000310X-24S	49	BK9416S*	11
2222-2	37	B-000075-M	67	B-000310X-24T	49	BK9416T*	11
2222-4	37	B-000100-M	67	B-000322-4S4	52	BK-9450-KIT	38
2223-2	36	B-000112-M	67	B-000322-6S4	52	BK9450R	17
2223-3	37	B-000125-M	67	B-000322-8S4	52	BK9450R	38
2233-6	36	B-000138-M	67	B-000322-12S4	52	BK 9452	13
2505AC	7	B-000150-M	67	B-000322-12T4	52	BK 9453	13
2505AC-80	38	B-000162-M	67	B-000322-16S4	52	BK 9453FA	13
2507AC	7	B-000200-M	67	B-000322-20S4	52	BK 9454	13
2507AC-80	38	B-00202X-4S4	54	B-000322-20T4	52	BK 9475A	13
2511AC	7	B-00202X-8S4	54			BKA8400R	38
2511AC-80	38						
2513AC	7						
2513AC-80	38						
2523HP-7	9						

Table of Contents

BKA8408S.....	11	ECL140.....	19	GS-00210W-24W3A.....	42	S-000232-4S4.....	46
BKA8412-80J.....	38	ECL325.....	19	GS-00210W-24W3J.....	42	S-000232-8S4.....	46
BKA8412-80JA.....	38	ES8450R.....	17	GS-00210W-24W3J.....	42	S-232HCB-4S4.....	46
BKA8412S.....	11	ES8450R.....	38	GS-00210W-32F.....	42	S-232HCB-4WA.....	46
BKA9408S.....	11	ES 8452.....	13	GS-00210W-32F3.....	42	S-232HCB-8S4.....	46
BKY8408-80AJ.....	38	ES 8453.....	13	GS-00210W-32W3A.....	42	S-232HCB-8WA.....	46
BR-1684M-80N.....	39	ES 8454.....	13	GS-00210W-32W3A.....	42	S-232HCB-12S4.....	46
BR-1686M-80N.....	39	GS-00110W-4S3.....	40	GS-00210W-32W3J.....	42	S-232HCB-12WA.....	46
BR-1780SC.....	39	GS-00110W-4S3.....	40	GS-00210W-32W3J.....	42	S-000886-4S.....	63
BR-1784-7SKA.....	39	GS-00110W-4T.....	40	HP1225-1.....	37	S-000886-4WA.....	64
BR-1784-7SKB.....	39	GS-00110W-4WA.....	40	HP1225-3.....	37	S-000886-6S.....	63
BR-1784-7SKC.....	39	GS-00110W-6S3.....	40	HP1225-4.....	37	S-000886-8S.....	63
BR-1784-80.....	39	GS-00110W-6S3.....	40	HP1227-1.....	37	S-000886-8WA.....	64
BR-1784-80E.....	39	GS-00110W-6WA.....	40	HP1227-3.....	37	S-000886-12S.....	63
BR-1784A.....	28	GS-00110W-8F.....	40	HP1227-5.....	37	S-000886-12WA.....	64
BR-1784B.....	28	GS-00110W-8S3.....	40	HP1227-9.....	37	S-000886-16W3A.....	64
BR-1784C.....	28	GS-00110W-8S3.....	40	HP1227-28.....	37	S-000886-24WA.....	64
BR-1784ST.....	39	GS-00110W-8WA.....	40	HP1228-1.....	36	S-000886-24WJ.....	64
BR-1786-7SKA.....	39	GS-00110W-12F.....	40	HP1228-2.....	36	S-000886-32W3J.....	64
BR-1786-7SKB.....	39	GS-00110W-12F3.....	40	HP1228-4.....	36	S-000886-32WA.....	64
BR-1786-7SKC.....	39	GS-00110W-12S3.....	40	LCR-B320.....	21	S-0886GF-4S.....	63
BR-1786-80.....	39	GS-00110W-12S3.....	40	LCR-B540.....	21	S-0886GF-6S.....	63
BR-1786-80E.....	39	GS-00110W-12WA.....	40	LCR-B580.....	21	S-0886GF-8S.....	63
BR-1786A.....	28	GS-00110W-16F.....	40	LCR-C320.....	21	S-0886GF-12S.....	63
BR-1786B.....	28	GS-00110W-16F3.....	40	LCR-C540.....	21	S-0886GF-12S.....	63
BR-1786C.....	28	GS-00110W-16S.....	40	LCR-C580.....	21	S-00886M-4S3.....	64
BR-1786ST.....	39	GS-00110W-16W3A.....	40	LV4286-10-5.....	35	S-00886M-8S3.....	64
BR-1788-7SKA.....	39	GS-00110W-16W3A.....	40	LV4286-10-8.....	35	S-00886M-12S3.....	64
BR-1788-7SKB.....	39	GS-00110W-16W3A.....	40	LV4403C2H42.....	32	S-00886M-16W3A.....	64
BR-1788-7SKC.....	39	GS-00110W-16W3J.....	40	M2523HP320.....	31	S-00886M-24W3A.....	64
BR-1788A.....	28	GS-00110W-16W3J.....	40	M2523HP326.....	31	S-00886M-24W3J.....	64
BR-1788B.....	28	GS-00110W-24F.....	40	M2523HP350.....	31	S-00886M-32W3J.....	64
BR-1788C.....	28	GS-00110W-24F3.....	40	M2523HP540.....	31	S-00886M-32WA.....	64
C-1682M.....	33	GS-00110W-24W3A.....	40	M2523HP580.....	31	S-886MGF-16W3A.....	64
C-1682MG.....	33	GS-00110W-24W3A.....	40	M2523HP590.....	31	S-886MGF-24W3A.....	64
C-1682ML.....	33	GS-00110W-24W3J.....	40	NR009432F022.....	22	SK9408BW.....	48
C-1682MLG.....	33	GS-00110W-24W3J.....	40	NR009432F050.....	22	SK9412BW.....	48
C-1682MS.....	33	GS-00110W-24W3J.....	40	NR009432F100.....	22	SK9416BW.....	48
C-1682MSG.....	33	GS-00110W-32F.....	40	NR009432T230.....	22	S1679.....	9
C-19434B235.....	26	GS-00110W-32F3.....	40	NR009432T250.....	22	T4403JS2.....	32
C-19434B250.....	26	GS-00110W-32F3.....	40	NR009432T300.....	22	T4403JT2.....	32
C-19434B280.....	26	GS-00110W-32W3A.....	40	NR009432T350.....	22	T9452.....	17
C-19434B300.....	26	GS-00110W-32W3A.....	40	NR009432T360.....	22	T9453.....	17
C-19434B350.....	26	GS-00110W-32W3J.....	40	PRV 19432.....	24	T9454.....	17
C-19434B375.....	26	GS-00110W-32W3J.....	40	PRV29432.....	24	T9464-80.....	38
CAP750.....	25	GS-00110W-48F.....	40	PRV19433.....	24	T9464ADA.....	17
CAP1000.....	25	GS-00110W-48F3.....	40	PRV29433.....	24	T9464CA.....	17
CAP1500.....	25	GS-00110W-48W3A.....	40	PRV19434.....	24	T9464DA.....	17
CAP2000.....	25	GS-00110W-48W3J.....	40	PRV29434.....	24	TNE1050-14400.....	36
CBC000125.....	20	GS-00110W-48W3A.....	40	RG-80.....	39	TNE1075-14400.....	36
CBC000300.....	20	GS-00110W-48W3J.....	40	RG-80A.....	39	UA3149A303.....	25
CBC000325.....	20	GS-00110W-48WA.....	40	RG125.....	19	UA3149A330.....	25
CBH000125.....	20	GS-00110W-48WJ.....	40	RG300.....	19	UA3149A358.....	25
CBH000300.....	20	GS-00210W-4S3.....	42	S-000006-M.....	67	VB-0206GF-2T6.....	55
CBH000325.....	20	GS-00210W-4S3.....	42	S-000012-M.....	67	VB-0206GF-4T6.....	55
CFE250A.....	14	GS-00210W-4T3.....	42	S-000018-M.....	67	VB-0206GF-6T6.....	55
CFE250G.....	14	GS-00210W-4T3.....	42	S-000025-M.....	67	VB-0206GF-8T6.....	55
CFM000002D.....	12	GS-00210W-6S3.....	42	S-000031-M.....	67	VB-0206GF-12T6.....	55
CFM000004D.....	12	GS-00210W-6S3.....	42	S-000038-M.....	67	VB-0206GF-16T6.....	55
CG250B.....	16	GS-00210W-6T3.....	42	S-000050-M.....	67	VB-226XGF-4T6.....	59
CG250BL.....	16	GS-00210W-6T3.....	42	S-000062-M.....	67	VB-226XGF-6T6.....	59
CG250SS.....	16	GS-00210W-8F.....	42	S-000075-M.....	67	VB-226XGF-8T6.....	59
CG250SSL.....	16	GS-00210W-8F3.....	42	S-000087-M.....	67		
CG375B.....	16	GS-00210W-8S3.....	42	S-000100-M.....	67		
CG375BL.....	16	GS-00210W-8S3.....	42	S-000112-M.....	67		
CG375SS.....	16	GS-00210W-8T3.....	42	S-000125-M.....	67		
CG375SSL.....	16	GS-00210W-8T3.....	42	S-000138-M.....	67		
CG500B.....	16	GS-00210W-12S3.....	42	S-000150-M.....	67		
CG500BL.....	16	GS-00210W-12S3.....	42	S-000162-M.....	67		
CG500SS.....	16	GS-00210W-16F.....	42	S-000200-M.....	67		
CG500SSL.....	16	GS-00210W-16F3.....	42	S-000231-2S4.....	44		
CG750B.....	16	GS-00210W-16W3A.....	42	S-000231-4S4.....	44		
CG750BL.....	16	GS-00210W-16W3A.....	42	S-000231-4WA.....	44		
CG750SS.....	16	GS-00210W-16W3J.....	42	S-000231-6S4.....	44		
CG750SSL.....	16	GS-00210W-16W3J.....	42	S-000231-8S4.....	44		
CGA580RL.....	18	GS-00210W-24F.....	42	S-000231-8WA.....	44		
CMM250A.....	14	GS-00210W-24F3.....	42	S-000231-12S4.....	44		
CMM250G.....	14	GS-00210W-24W3A.....	42	S-000231-12WA.....	44		
CW6600G-80.....	38						
ECL22.....	19						
ECL70.....	19						
ECL-80.....	39						
ECL-80A.....	39						

High Pressure Gas Master Valves 9560 Series

Application

The 9560 Series high pressure brass valves are used on cylinder filling panels, tube trailers, and other high pressure manifolds and piping systems. The 9560 Series exhibits a very low operating torque under pressure for ease of manual operation.

Features

- 4200 psig maximum working pressure with a 5 to 1 safety factor.
- 5600 PSI maximum working pressure with a 4 to 1 safety factor
- Non-rising stem design with O-Ring Seal for durable service.
- Large brass handwheel for easy low torque operation under pressure.
- All valves cleaned for use in oxygen per CGA G-4.1.
- Temperature range -40°F to +165°F.
- 100% Factory Tested

Materials

Body, bonnet, stem, and seat retainer, stem seal retaining rings and washer	Brass
Stem O-ring	Viton
Handwheel Washer	PTFE

Soft Seat Option

The soft seat valves use a CTFE seat disc in the seat retainer to create a "bubble-tight" seal against a machined seat surface on the brass body. Valve Cv is 2.6. The soft seat option is especially useful for small molecule gases like hydrogen and helium, but can be used for a variety of non-corrosive industrial gases including oxygen, argon, nitrogen, carbon dioxide, nitrous oxide, and acetylene.

Metal Seat Option:

A copper seat disc is used in the seat retainer to create a seal against a Monel body seat, which is installed into the body and can be replaced. Valve Cv is 2.3. The metal seat option minimizes the possibility of seat decomposition or ignition in oxygen service under adiabatic compression. The metal seat option is recommended for oxygen, and can also be used for other non-corrosive industrial gases. The metal seat option is not to be used for acetylene due to the copper seat. Not to be applied in hydrogen or helium service or where a "bubble-tight" seal is essential. (Note: C in part number)

Bonnet Versions

- Standard Bonnet for low profile.
- Panel Mount Bonnet for ease of panel installation. Includes threaded bonnet and nickel plated brass mounting nut. Metal Seat Option 1.625" diameter panel hole required for mounting. (Note: P in part number)

HP Version

- With metal seat option.
- 5600 psig maximum working pressure with 4 to 1 safety factor. Use "HP" prefix for metal seat. (ex. HP9560CB). Nylon seat option available also (ex. 9560NB).



STANDARD BONNET VALVE



PANEL MOUNT VALVE

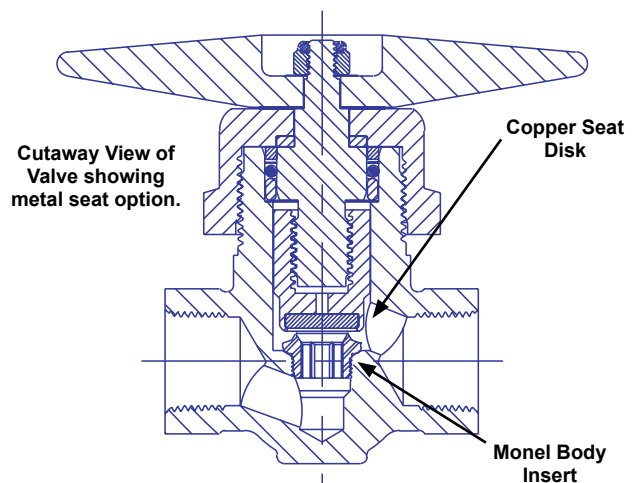

High Pressure Gas Master Valves 9560 Series

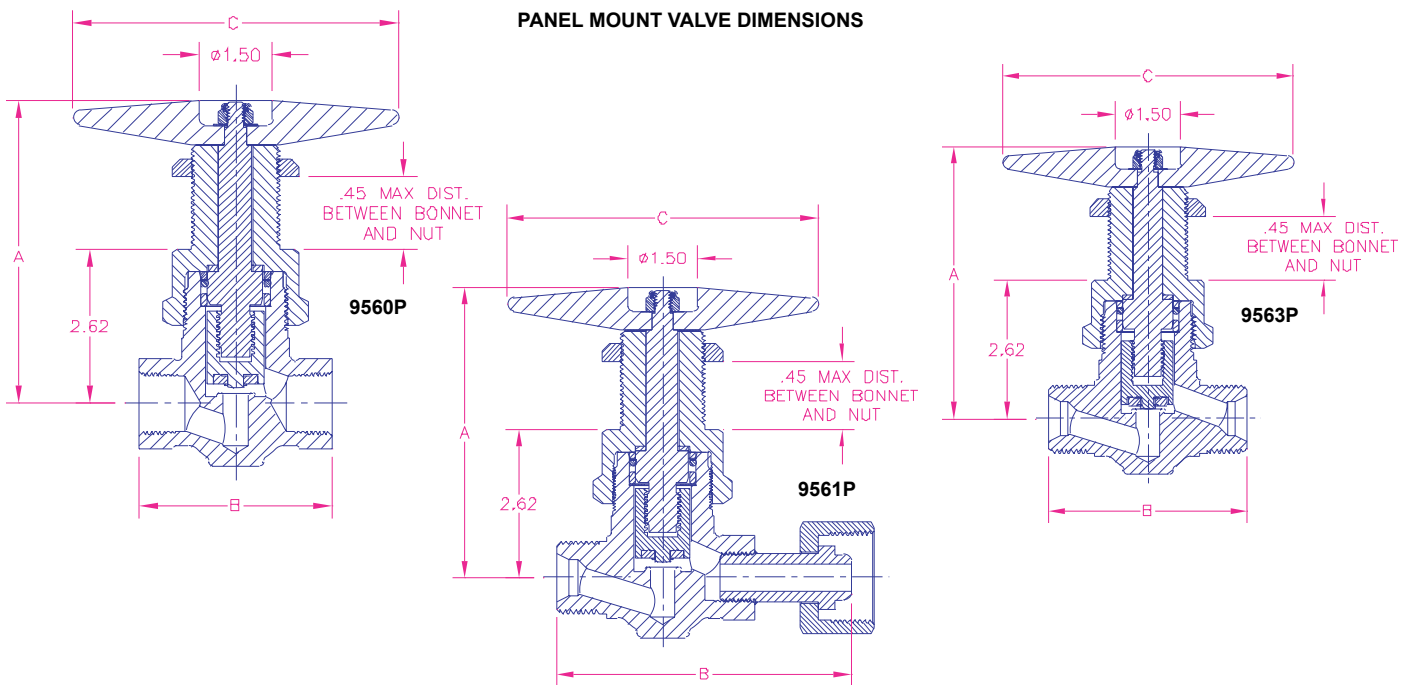
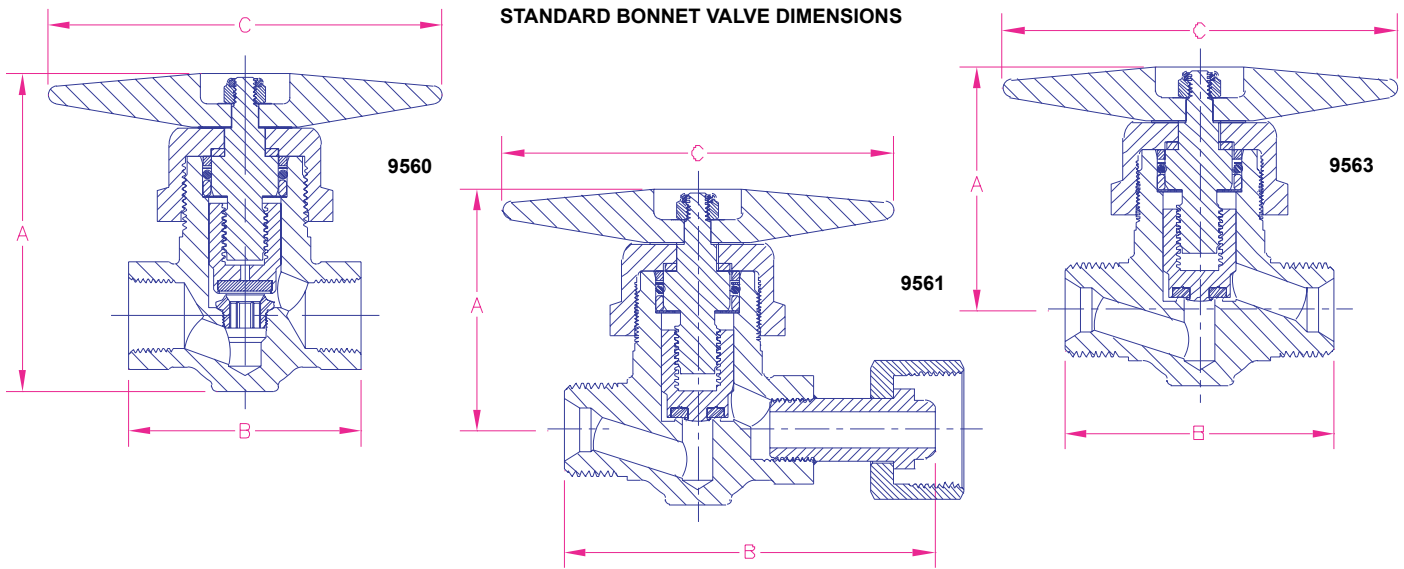

Ordering Information

Part Number		Inlet Connection	Outlet Connection	Height A	Height B	Height C
Soft Seat	Metal Seat					
9560A	9560CA	½" F. NPT	½" F. NPT	4.36" *[6.19" for panel mount version]	3.25"	5.5"
9560B	9560CB	¾" F. NPT	¾" F. NPT		5.27"	
9561R	9561CR	1"-11½" NPSM R.H.	1"-11½" R.H. Female Swivel		3.79"	
9561RL	9561CRL	1"-11½" NPSM R.H.	1"-11½" NPS L.H. Female Swivel		3.25"	
9561L	9561CL	1"-11½" NPSM L.H.	1"-11½" L.H. Female Swivel			
9563R	9563CR	1"-11½" NPSM R.H.	1"-11½" NPSM R.H.			
9563L	9563CL	1"-11½" NPSM L.H.	1"-11½" NPSM L.H.			
9560ASE	9560CASE	.843 - .847	.843 - .847			
9560BSE	9560CBSE	1.053 - 1.057	1.053 - 1.057			
9560BSE-B	9560CBSE-B	1.053 - 1.057	¾" F.NPT			

*Place "P" at end of part number for panel mount version.

Diaphragm Type Globe Valves 2550 Series

Application

The 2550 series valves are designed for use in hospital and industrial piping systems where gases are supplied from a central source to branch outlets throughout the system.

Features

- UL listed for use with air, acetylene, hydrogen, LP-Gas, nitrogen, and oxygen service.
- Leakage is prevented by a dependable diaphragm stem seal.
- A resilient seat disc provides positive shut-off.
- Heavy duty ACME stem threads assure easy operation and long working life.
- Maximum working pressure is 250 PSIG.
- Working temperature range is -40°F to +165°F.
- 100% Factory Tested



2554AC

Materials

Body (2553 series)	Forged Brass
Body (2554 series)	Cast Bronze, Tin Plated
Handwheel.....	Aluminum
Seat Disc	Filled Teflon
Diaphragm.....	Neoprene
Bonnet	Brass
Stem	Manganese Bronze

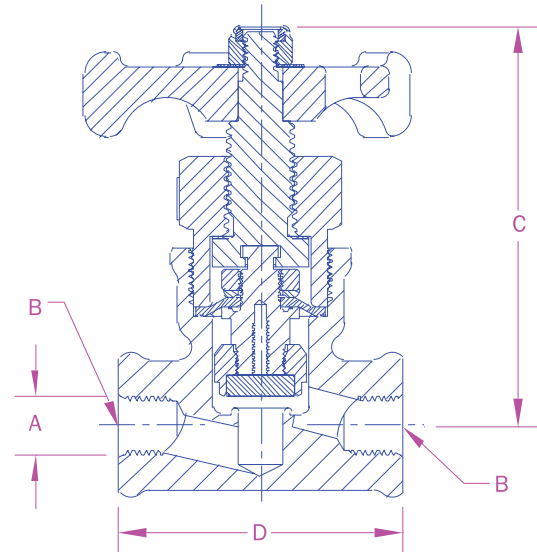

Ordering Information

Part Number	Inlet/Outlet Thread (Female NPT) A	Port Diameter B	Height C	Length D	Cv Factor
2553AC	1/4"	13/32"	3 3/8"	2 1/2"	1.4
2553AAC	3/8"				1.5
2554AC	1/2"	1 1/16"		3 1/8"	4.3
2554AAC	3/4"				4.3

Diaphragm Type Globe Valves 2500 Series

Application

The 2500 series valves are designed for use in hospital and industrial piping systems where gases are supplied from a central source to branch outlets throughout the system.

Features

- UL listed for use with air, argon, acetylene, helium, hydrogen, LP-Gas, nitrogen, inert gases and oxygen service.
- Leakage is prevented by a dependable diaphragm stem seal.
- A resilient seat disc provides positive shut-off.
- Heavy duty ACME stem threads assure easy operation and long working life.
- Unique back seat design allows the diaphragm assembly to be repaired while the valve remains in service.
- Maximum working pressure is 400 PSIG.
- Working temperature range is -40°F to +165°F.
- 100% Factory Tested



2505AC

Materials

Body Cast Bronze, Tin Plated
 Bonnet Brass
 Stem Manganese Bronze
 Seat Disc Neoprene
 Diaphragm Neoprene

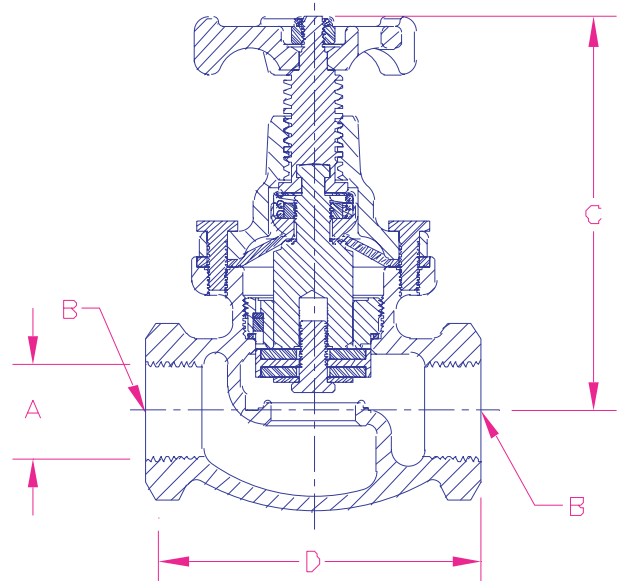

Ordering Information

Part Number	Inlet/Outlet Thread (Female NPT) A	Port Diameter B	Height C	Length D	Cv Factor
2505AC	3/4"	15/16"	5 1/4"	4"	9.0
2507AC	1"	1 1/8"	5 3/8"	4 3/8"	15.0
2511AC	1 1/2"	1 11/16"	6 3/4"	5 3/8"	33.4
2513AC	2"	2 5/16"	7 1/4"	6 1/4"	51.7

Line Station Valves 7160 Series

Application

The 7160 series valves are designed for use with oxygen and all fuel gases at station outlets of line distribution systems such as welder's benches, cutting stations, hospital rooms, etc.

Features

- UL Listed
- Approved for oxygen and all fuel gas services at 400 PSIG maximum working pressure.
- O-ring stem seal works with the pressure causing a tighter seal as pressure increases.
- A reverse flow check valve installed in the valve outlet connection helps prevent reverse flow.
- Available with brass cap and chain protection.
- Meets the requirements of National Fire Protection Association (NFPA) Pamphlet No. 51.



Materials

Body Brass
 Stem and Seat Retainer Brass
 O-ring..... Neoprene
 Seat Disc Nylon
 Reverse Flow Check Seat..... Neoprene

7160 Series

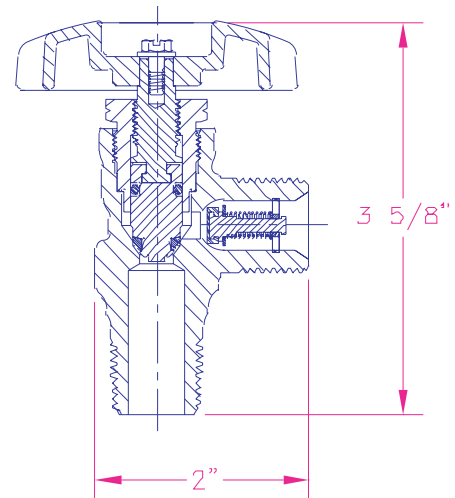

Ordering Information

Part Number	Gas Service	Inlet Thread	Outlet Thread	CGA Connection	Cv Factor	Outlet Protection*
7160V	Oxygen and Inert Gases	1/2" NGT	7/8" - 14 M. R.H.	024	.76	10663 Brass Cap & Chain
7160VL						None
7161V	Fuel Gases	1/2" NGT	7/8" - 14 M. L.H.	025		10664 Brass Cap & Chain
7161VL						None

*Outlet Protection is recommended.

Pressure Gauges

Application

Pressure gauges are available in a variety of popular pressure ranges for gas plant applications.

Gauges should be selected so that the maximum working pressure of the particular system represents 66% to 75% of the maximum gauge reading. Greater safety and accuracy may be realized by following these guidelines.

All pressure gauges have a 1/4" NPT male outlet Bottom Connection



15578

Ordering Information

Part Number	Maximum Calibration (PSIG)	Size	Increment Division (PSIG)	Case Material
1286	100	2"	2	Steel
2523HP-7	160		5	
S1679	200		10	Brass
15578	400		50	Steel
5562C	4000			

Brass Plugs

(for pressures to 3000 PSIG)
Safety factor = 5:1

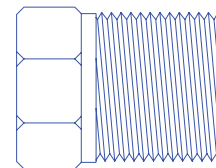

Typical Plug

Ordering Information

Part Number	Thread Connection	Hex Flats
985B	1/4" NPT	9/16"
985D	1/2" NPT	7/8"
985E	3/4" NPT	1 1/8"
985F	1" NPT	1 3/8"

Brass Outlet Cap and Chain Assemblies

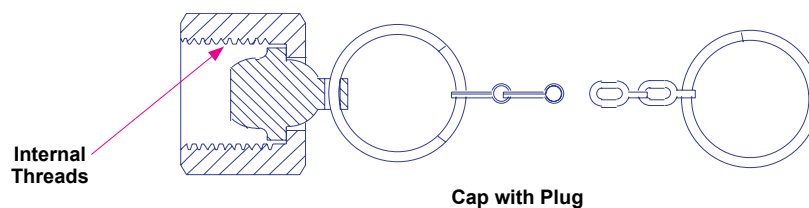

Cap with Plug

Ordering Information

Part Number	Thread Connection	End Ring Fits Pipe
10663	7/8"-14NF-RH	1/2"
10664	7/8"-14NF-LH	1/2"

Extended Bonnet Cryogenic Globe Valves BK and BKA Series Valves

Application

The BK and BKA Series valves are designed exclusively for the handling of cryogenic liquids on bulk storage tanks, transports, and pipelines. These globe valves provide positive shutoff and offer a long, low-maintenance service life. The valves are available with a variety of inlet and outlet connections and stem lengths. Certain BK valves are offered with brazed-in Sch 5 Stainless Steel Pipe Stubs.

Features

- CTFE seat disc and swivel seat design offer positive shutoff, minimal seat wear, and a long service life.
- Unique spring-loaded upper packing provides extended service life without constant packing adjustment
- One piece slip-on seat assembly for easy replacement.
- Each valve is pressure tested to be leak free.
- Each valve is cleaned and packaged for oxygen service per CGA G-4.1.
- Maximum working pressure is 600 psig CWP.
- Working temperature range is -320°F to +165°F.
- 100% Factory Tested

Materials

Body	Bronze
Body and Bonnet	Brass
Seat Disc	CTFE
Seat Retainer Assembly	Brass
Stem and Bonnet Extension Tube	Stainless Steel
Packing Spring, Washer	Stainless Steel
Jam Ring and Pressure Seal Rings	PTFE
Upper Bonnet, Packing Gland	Brass
Handwheel	Aluminum for up to 1" valve size, Coated Malleable Iron for larger size

Bonnet Design

Union Bonnet for 1/2", 3/4", 1" valve sizes and on both the 1" model BKA8408S and 1 1/2" model BKA8412S angle valves. Bolted Bonnet design is used on the BK9410, BK9412, and BK9416 models.



BK 8408T

BK 9412S

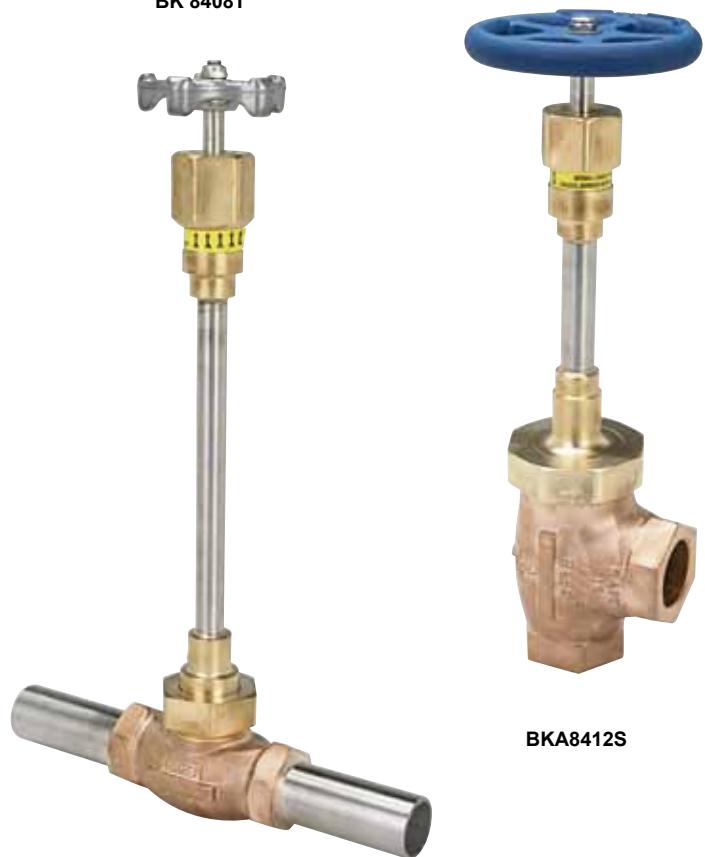

BKA9408AA

BKA8412S

Extended Bonnet Cryogenic Globe Valves BK and BKA Series Valves

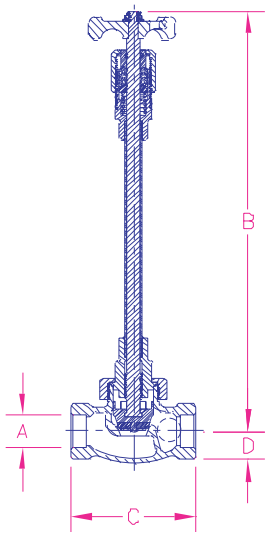

Straight Globe Valve

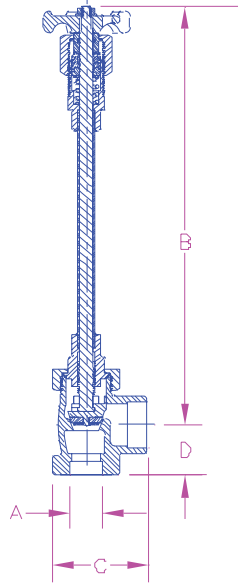

Angle Globe Valve

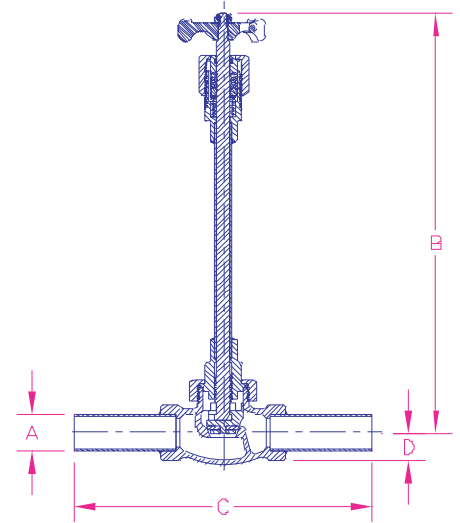

Straight Globe Valve with Pipe Stubs

Ordering Information

Part Number	Body Style	Inlet / Outlet Connections A	Max Open B (Approx)	Length C	D	Cv Factor	
BK8404S	Straight	.631"-.634"	9 5/32"	3 11/16"	1"	4.7	
BK8404T		1/2" F.NPT					
BK8404ST		.631"-.634"x 1/2" F.NPT					
BK9404S		.631"-.634"	14 1/2"	3 11/16"	1"	4.7	
BK9404T		1/2" F.NPT					
BK9404AA		1/2" Sch5 Pipe					
BK9404PT-F30		1/2" Sch5 Pipe x 1/2" F.NPT	9 11/16"	6 11/16"	1"	4.7	
BK9404ST		.631"-.634"x1/2" F.NPT					
BK8406S		.881"-.884"					9 5/32"
BK8406T		3/4" F.NPT					
BK9406S		.881"-.884"	14 1/2"	3 11/16"	1"	6.7	
BK9406T		3/4" F.NPT					
BK8408S		1.131"-1.134"					9 1/8"
BK8408T		1" F.NPT					
BK9408S		1.131"-1.134"	14 1/2"	4 5/16"	1 1/8"	11.2	
BK9408T		1" F.NPT					
BK9408AA		1" Sch5 Pipe					10 5/16"
BK9408PT-F30		1" Sch5 Pipe x 1" F.NPT					
BK9410S*		1.378"-1.380"	16 7/16"	5 13/16"	1 1/2"	17.5	
BK9412S*		1.631"-1.634"					
BK9412T*		1 1/2" F.NPT					16 9/16"
BK9412AA		1 1/2" Sch5 Pipe					
BK9412PT-F30		1 1/2" Sch5 Pipe x 1 1/2" F.NPT	8 3/16"	1 5/8"	41		
BK9416S*		2.131" - 2.134"					
BK9416T*		2" F.NPT				16"	6"
BK9416PT-F30		2" Sch5 Pipe x 2" F.NPT	9"				
BKA8408S		Angle		1.131" - 1.134" x 1.631"	9 5/11"	3 1/4"	1 3/4"
BKA9408S			- 1.634"	14 5/8"			
BKA8412S			1.631"-1.634"	13"	4 1/4"		

* Valves with bolted bonnet design.

RegO Cryogenic Fill Manifold CFM, AFM & SFM Series

Application

Direct replacement for cryogenic fill modules in bulk vessel applications. Our factory-brazed assembly includes top and bottom fill valves, fill check and hose evacuation valve.

Features

- Precision silver brazed assembly
- Repeatable performance and geometry
- 100% factory tested
- Temperature range -320° to +165° F

CFM: Union Bonnet Bronze Construction with Stainless Steel Tube 304L

AFM: Bolted Bonnet Bronze Construction with Stainless Steel Tube 304L

SFM: Bolted Bonnet Stainless Steel Construction with Stainless Steel Tube 304L

Materials

CFM Style

Body Bronze
 Bonnet Brass
 Seat Disc CTFE
 Seat Retainer Assembly Brass
 Stem and Bonnet Extension Tube Stainless Steel
 Packing Spring, Washer Stainless Steel
 Jam Ring and Pressure Seal Rings PTFE
 Upper Bonnet and Packing Gaurd Brass
 Handwheel Coated Malleable Iron
 Tube 304L Stainless Steel Tube

AFM Style

Body Bronze
 Bolted Bonnet Bronze
 Bonnet Fasteners (Bolts) Stainless Steel
 Seat Disc PCTFE (Neoflon®)
 Stem and Bonnet Extension Tube Stainless Steel
 Live Loaded Packing PTFE and Brass
 Live Loaded Washers Stainless Steel
 Handwheel Chromate Coated Ductile Iron
 Tube 304L Stainless Steel Tube

SFM Style

Body Stainless Steel
 Bolted Bonnet Stainless Steel
 Bonnet Fasteners (Bolts) Stainless Steel
 Seat Disc PCTFE (Neoflon®)
 Seat Retainer Brass
 Packing Spring & Washer Stainless Steel
 Bonnet Gasket PTFE (Teflon®)
 Handwheel Chromate Coated Ductile Iron
 Tube 304L Stainless Steel Tube

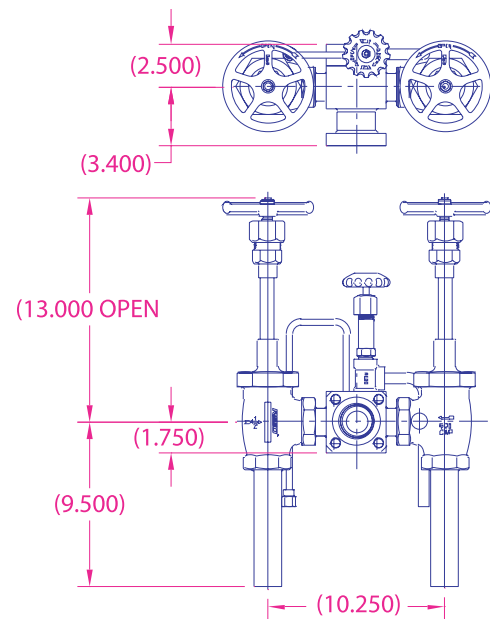

Ordering Information

Part Number	Piping Size
CFM000002D	1"
CFM000004D	1½"
AFM000004D	1½"
SFM000004D	1½"

ES8450 Series Extended Stem Valves BK9450 & BK9470 Series Extended Bonnet Valves

Application

These valves are designed for use as a trycock valve or hose drain valve on cryogenic tanks. Another application is as a use, liquid fill, or vent valve on mini-bulk cryogenic tanks. These valves can be used likewise for other cold gas applications requiring extended stem valves as LNG Fueling.

Features

- Union bonnet.
- One piece stainless steel stem
- Conical seat design.
- Maximum working pressure is 600 psig.
- Working temperature is -320°F to +165°F.
- Cleaned for oxygen service per CGA G-4.1.
- 100% Factory Tested

ES8450 Series specific feature:

- Manual torque compression packing.

BK9450 and BK9470 Series specific feature:

- Extended bonnet and spring loaded packing.

BK9470 Series specific feature:

- 304 St. Stl Tube brazed into one or both ends.

Materials

Body and Bonnet Brass
 Stem Stainless Steel
 Seat Disc CTFE
 Handwheel..... Aluminum
 Packing and Bonnet Gasket..... PTFE

Conversion Kit

BK 9450-KIT is a bonnet and stem assembly kit to convert ES 8450 Series and previous ES 9450 Series to the BK 9450 style.

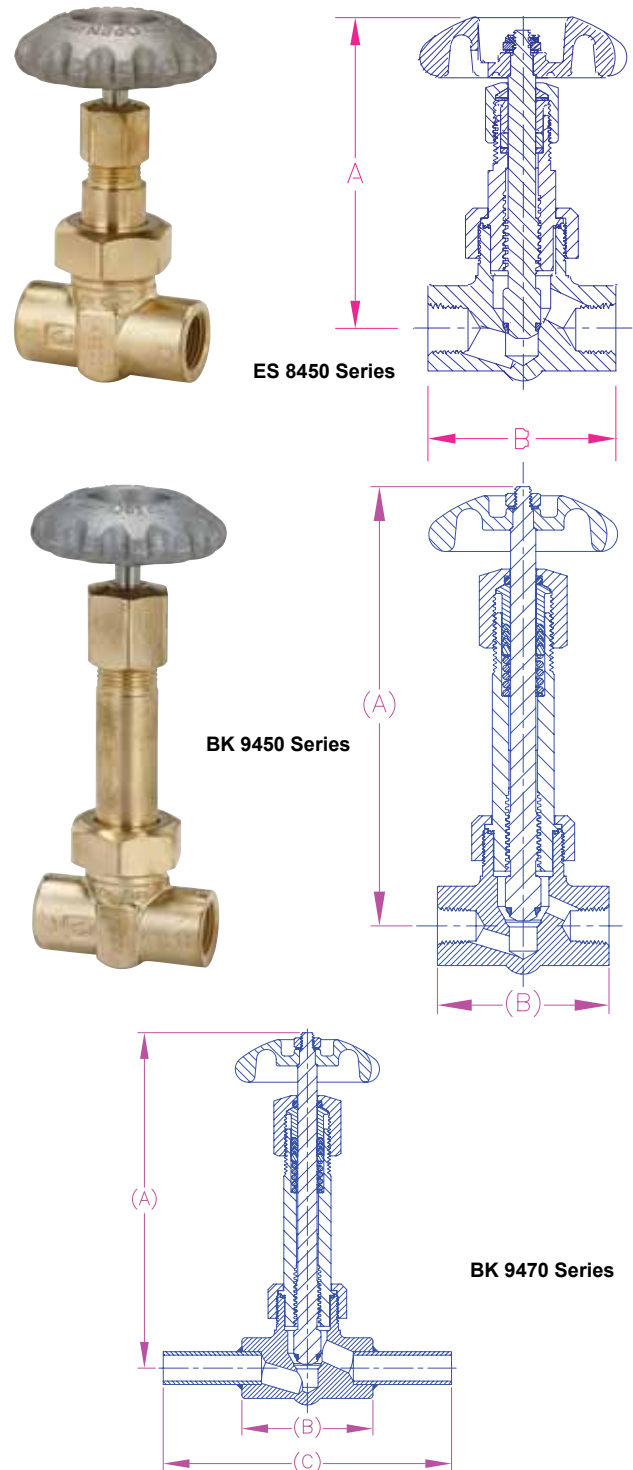

Ordering Information

Part Number	Inlet/Outlet Connections	Height "A"	Body Width "B"	Width with Tube "C"	Cv	
ES 8452	1/4" FNPT	4"	2.5"		0.70	
ES 8453	3/8" FNPT	4"			1.10	
ES 8454	1/2" FNPT	4"			1.10	
BK 9452	1/4" FNPT	6.5"			0.70	
BK 9453	3/8" FNPT	6.5"			1.10	
BK 9454	1/2" FNPT	6.5"			1.10	
BK 9453FA	5/8" OD tubing x 3/8" FNPT	6.5"			4.0"	1.10
BK 9475A	5/8" OD tubing both ends	6.5"			5.5"	1.10

Needle Valves CMM250 Series and CFF250 Series

Application

Ideal for use as a gauge isolation valve or applications requiring accurate throttling of pressure.

Features

- Compact design provides easy installation.
- Fine stem threading and long taper allow precise metering and leak-free shut-off.
- Internal stop prevents the stem from being accidentally unscrewed from the body.
- Rugged forged brass bodies withstand higher pressures.
- Unbreakable brass handwheel.
- Valves come equipped for panel mounting.
- Working temperature range is -40°F to +165°F.
- Maximum operating pressure: 2000 psig air.
- Cleaned for oxygen service per CGA G-4.1.
- Female ports available - consult factory.

Materials

Body	ASTM B283 Brass
Stem	Brass
Knob	Brass
Bonnet Nut.....	Brass
Panel Mount Nut (Optional).....	Brass
Set Screw	Steel
Stem Packing	PTFE with Brass Gland

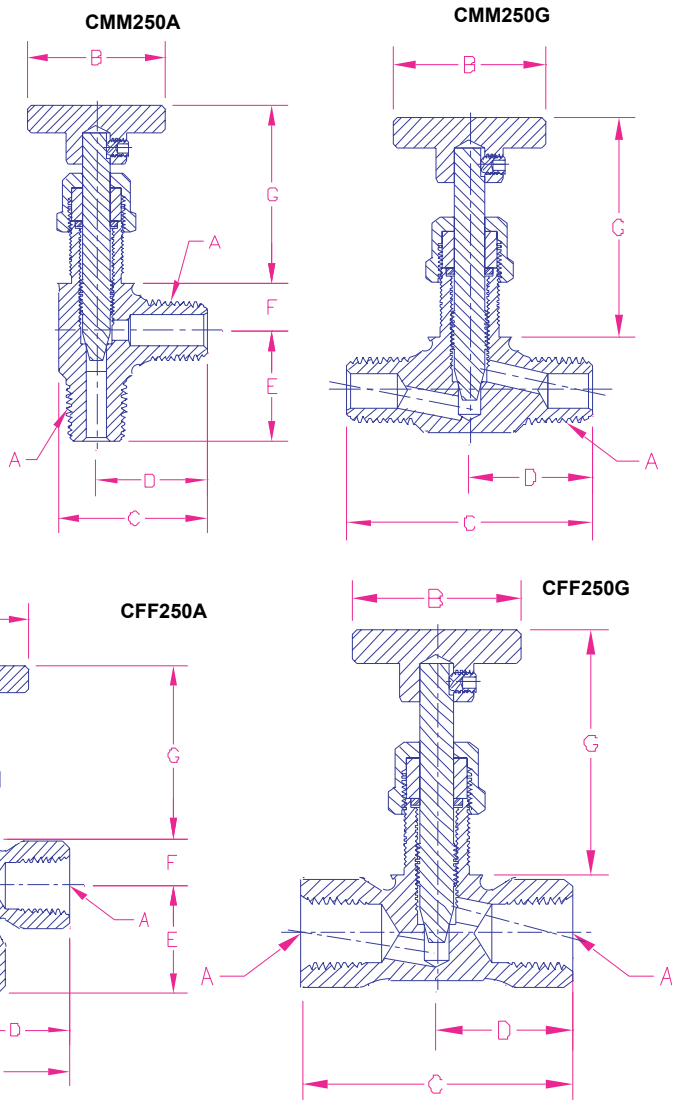

Ordering Information

Part Number	A (NPT)	B (In.)	C (In.)	D (In.)	E (In.)	F (In.)	G (In.) Open	G (In.) Closed	Cv
CMM250A	¼	1¼	1 ¹¹ / ₃₂	1	1	7/16	2 ⁵ / ₃₂	1 ¹⁹ / ₃₂	.7
CMM250G	¼	1¼	2	7/8		7/16	2 ⁵ / ₃₂	1 ¹⁹ / ₃₂	.5
CFF250A	¼	1¼	1 ¹³ / ₃₂	¾	1	7/16	2 ³ / ₁₆	1 ⁵ / ₈	.7
CFF250G	¼	1¼	2	1		7/16	2 ³ / ₈	1 ¹³ / ₁₆	.5

Horizontal Check Valves 8500 Series

Application

The 8500 series valves are designed for use as a check valve on large cryogenic bulk stations and cryogenic pipelines.

Features

- Replaceable Kel-F seat discs.
- Self-centering cap holds plunger in position.
- Each valve is cleaned and packaged for liquid oxygen service per CGA G-4.1.
- 100% Factory Tested
- Working temperature range is -320°F to +165°F.
- Maximum working pressure is 600 PSIG CWP.
- 2 PSI opening pressure.



BK8508S

Materials

Body Bronze
 Cap Brass or Bronze
 Plunger Brass
 Seat CTFE

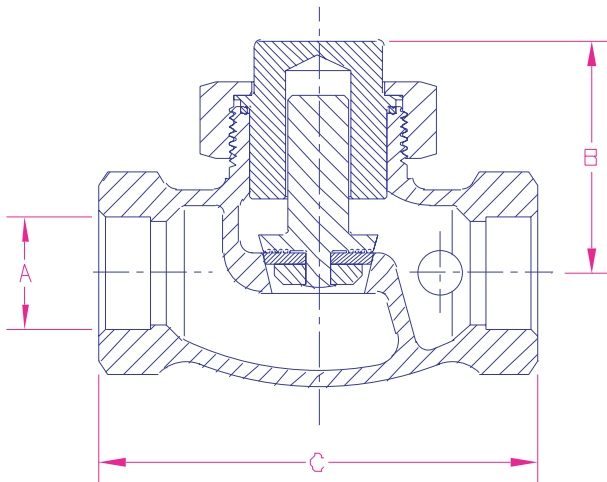

BK8512S

Ordering Information

Part Number	Inlet / Outlet Connection A	B	Length C	Cv Factor
BK8508S	1.128"-1.130"	2¼"	4 ¹⁵ / ₁₆ "	10
BK8508T	1" F.NPT			
BK8512S	1.629"-1.631"	3¼"	5 ³ / ₁₆ "	27
BK8512T	1½" F.NPT			

Inline Check Valves

CG Series Gas and Cryogenic Check Valves

Application

Inline check valves with metal seat option for cryogenic service or with soft seat option for leak free operation in gas service.

Features

- One directional flow indicated by arrow on body.
- Large Cv for high flow capability and low pressure drop.
- Working temperature range:
-320° F to +165° F for metal seats.
-20° F to +165° F for soft seats.
- 1 psig opening pressure.
- Cleaned for use in oxygen service per CGA G-4.1



Materials

Body (B and BL suffix) ASTM B16 Brass
 Body (SS and SSL suffix) 203 Stainless Steel
 Spring Stainless Steel
 Piston Stainless Steel
 O-Ring (soft seat option units only) Viton
 Metal Seat 303 Stainless Steel

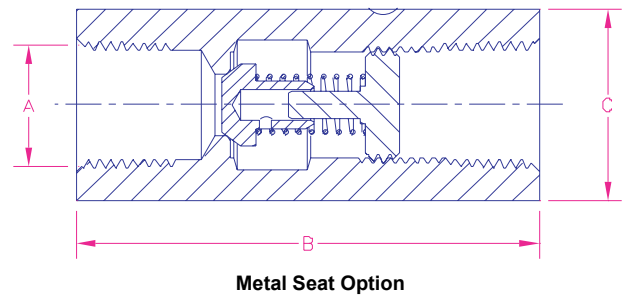
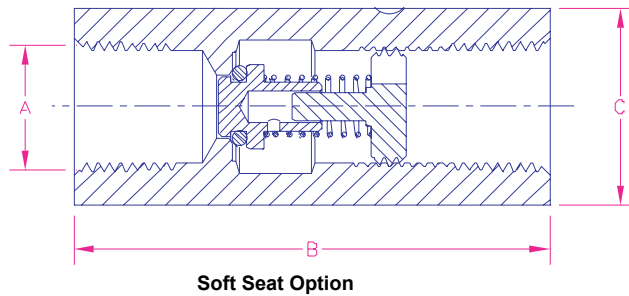

Ordering Information

Part Number	Seating Option	Inlet/Outlet Connections FNPT A	Length B	Wrenching Hex Size C	Cv	Maximum Operating Pressure
Stainless Steel Check Valves						
CG250SS	Metal	1/4"	2 ³ / ₈ "	1 ³ / ₁₆ "	.87	5000 PSIG
CG375SS	Metal	3/8"	2 ¹ / ₂ "	1"	2.3	5000 PSIG
CG500SS	Metal	1/2"	3"	1 ¹ / ₈ "	3.5	5000 PSIG
CG750SS	Metal	3/4"	3 ⁵ / ₈ "	1 ¹ / ₂ "	5.2	5000 PSIG
CG250SSL	Soft	1/4"	2 ³ / ₈ "	1 ³ / ₁₆ "	.87	250 PSIG
CG375SSL	Soft	3/8"	2 ¹ / ₂ "	1"	2.3	250 PSIG
CG500SSL	Soft	1/2"	3"	1 ¹ / ₈ "	3.5	3000 PSIG
CG750SSL	Soft	3/4"	3 ⁵ / ₈ "	1 ¹ / ₂ "	5.2	3000 PSIG
Brass Body Check Valves						
CG250B	Metal	1/4"	2 ³ / ₈ "	1 ³ / ₁₆ "	.87	3000 PSIG
CG375B	Metal	3/8"	2 ¹ / ₂ "	1"	2.3	3000 PSIG
CG500B	Metal	1/2"	3"	1 ¹ / ₈ "	3.5	3000 PSIG
CG750B	Metal	3/4"	3 ⁵ / ₈ "	1 ¹ / ₂ "	5.2	3000 PSIG
CG250BL	Soft	1/4"	2 ³ / ₈ "	1 ³ / ₁₆ "	.87	250 PSIG
CG375BL	Soft	3/8"	2 ¹ / ₂ "	1"	2.3	250 PSIG
CG500BL	Soft	1/2"	3"	1 ¹ / ₈ "	3.5	3000 PSIG
CG750BL	Soft	3/4"	3 ⁵ / ₈ "	1 ¹ / ₂ "	5.2	3000 PSIG

Short Stem Cryogenic Valves T9450 Series & T9460 Series

Application

π

The T9450 and T9460 series valves are designed for use on portable cryogenic cylinders and other in-line shut-off valve applications. Approved for TPED in accordance with EN1626.

Features

- Spring loaded stem seal automatically adjusts for any gasket wear, eliminating the need to constantly retighten the packing nut.
- Non-rising stem and low profile allow the valve to fit into tight areas and still provide easy access.
- Unique pressure-sealed moisture barrier helps prevent freeze up at cryogenic temperatures.
- Conical swivel seal design helps prevent seat galling from over torquing.
- Cleaned for liquid oxygen service per CGA G-4.1.
- Maximum working pressure is 600 PSIG.
- Working temperature range is -320°F to +165°F.
- 100% Factory Tested

Materials

Body	Brass
Bonnet	Brass
Seat Disc	CTFE
Stem Seal Gasket.....	PTFE
Handwheel.....	Aluminum
Spring	Stainless Steel
Upper Stem	Brass
Lower Stem	Manganese Bronze

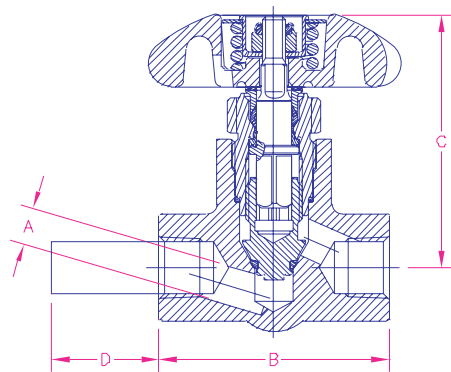

Ordering Information

Part Number	Inlet	Outlet	Orifice A	Length B	Height (Approx.) C	Tube D	Cv Factor
T9452	¼" F.NPT	¼" F.NPT	.250	2½"	2¾"	None	.72
T9453	⅜" F.NPT	⅜" F.NPT	.406				1.08
T9454	½" F.NPT	½" F.NPT	.406				1.10
T9464CA	.675 Tube	⅜" F.NPT	.406	2½"	2¾"	1⅝"	1.08
T9464DA						2⅛"	
T9464ADA						3⅞"	

Extended Stem Retrofit Kits

Application

These retrofit kits can be used to convert the 9450 and 9460 series short stem shut off valves into extended stem style. The conversion can be done without removing the valve from your system. Available in two stem lengths. All kits are oxygen cleaned and packaged per CGA G-4.1.

Materials

Body	Brass
Seat Disc	CTFE
Handwheel.....	Aluminum
Packing.....	PTFE
Stem	Stainless Steel
Stem Seal Gasket.....	PTFE

Ordering Information

Part Number	Stem Length A	Style
ES8450R	4"	Extended Stem, Std. Bonnet, Manual Packing
BK9450R	6.5"	Extended Bonnet and Stem, Spring Loaded Packing

REGO-LOK™ for Securing CGA Fittings on Liquid Cylinders

Application

The REGO-LOK™ is designed for installation on the Rego T9450 and T9460 Series liquid cylinder valves to deter and prevent the removal of the CGA fitting from the valve. The REGO-LOK™ retains standard CGA outlet connection fittings so unauthorized persons do not remove the fitting. By use of a special one-way bolt, the REGO-LOK™ is secured to the valve. The REGO-LOK™ installs in a few minutes with the use of screwdrivers. REGO-LOK™ installs without valve disassembly, brazing, welding, or drilling. The REGO-LOK™ deters and prevents fitting removal by gas customers, however allows the replacement of fittings by authorized gas supplier plant personnel.

Use REGO-LOK™ for compliance with CGA SB-26 for medical and industrial liquid cylinders.

Features

- Stainless Steel REGO-LOK™ with one-way bolt.
- Retrofit all common liquid cylinder valves.
- Can be supplied on new Rego liquid cylinder valves.
- REGO-LOK™ indicates "WARNING: DO NOT REMOVE"
- Worn CGA fittings can be simply replaced by authorized personnel. Requires new 9464RL-6 Bolt
- Can fit over existing fittings for CGA 540, CGA 440, CGA 295, CGA 320, and CGA 326. Check fitting hex size.
- *NOTE: Rego supplied fitting P/N CGA580RL is required for REGO-LOK™ use with CGA 580 connection.*
- Prevents loosening of CGA fittings on valves.

Rego-Lok™



Satisfies CGA SB-26 and FDA requirements for medical and industrial liquid cylinders.

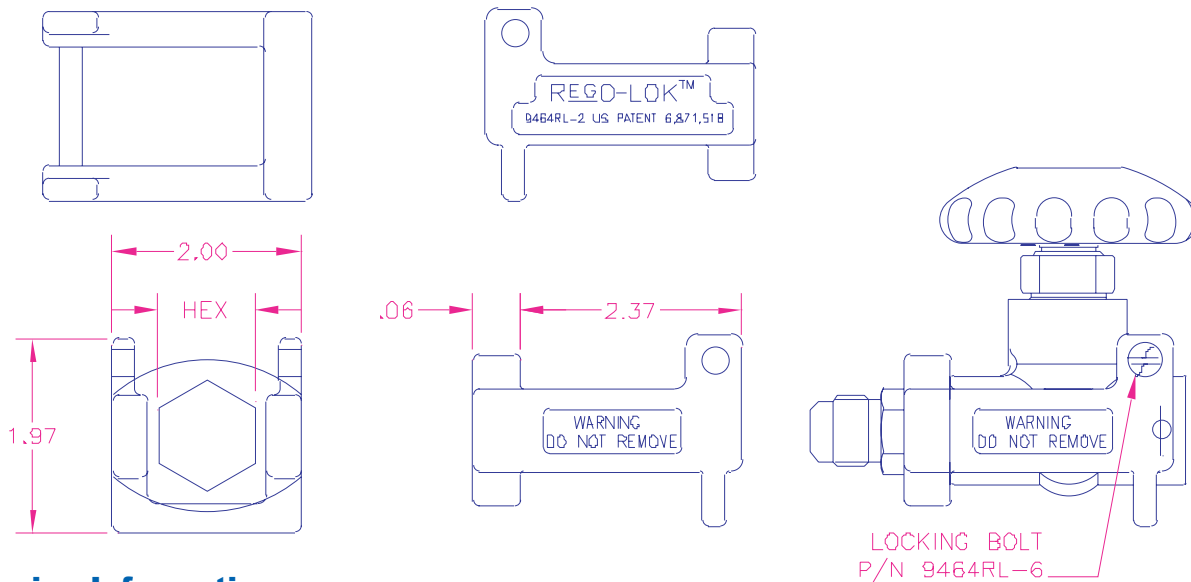

Ordering Information

Part Number	Item Description	Typical Service Connection
9464RL-0	REGO-LOK™ for 3/4" hex fittings	CGA 295
9464RL-1	REGO-LOK™ for 7/8" fittings	CGA 440, CGA 320 & CGA 326
9464RL-2	REGO-LOK™ for 1" fittings	CGA 540
9464RL-3	REGO-LOK™ for 1 1/8" hex CGA 580RL fitting by Rego	CGA 580
CGA580RL	3/8" MNPTxCGA for use with 9464RL-3	CGA 580

REGO-LOK™ is a registered trademark of Rego Patent applied for.

Cryogenic Regulators RG Series

Application

The RG series cryogenic regulators are primarily designed to maintain pressure on cryogenic liquid within cryogenic containers. They may also be used in cryogenic lines, vaporizer and converter applications. They are especially useful in installations where space and cost limitations are important.

Features

- All parts are copper alloy (brass), PTFE and stainless steel—materials selected specifically for compatibility with cryogenic temperatures down to -320°F.
- Body and bonnet machined from solid brass bar stock.
- PTFE seat helps assure a positive shut-off at cryogenic temperatures down to -320°F.
- High and low pressure regulators are the same compact size—designed to fit in close quarters.
- Interchangeable with existing cryogenic regulator units.
- Inlet filter helps prevent foreign material from entering the regulator.
- Locknut is provided to maintain adjusting screw setting.
- Maximum inlet pressure of 550 PSIG.
- Cleaned for liquid oxygen service per CGA G-4.1
- 100% Factory Tested

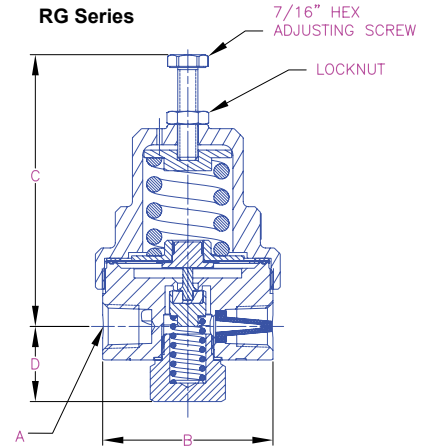

Materials

Body	Brass
Bonnet	Brass
Seat Retainer.....	Brass
Seat	PTFE
Springs	Stainless Steel
Diaphragm Gasket.....	PTFE
Backcap Gasket	Copper
Diaphragm	Bronze

Ordering Information

Part Number	Inlet / Outlet Connections (F.NPT) A	Width B	C	D	Pressure Setting (PSIG)	Operating Range (PSIG)
RG125A	1/4"	2 1/16"	3"	1"	125	25-250
RG300A					300	125-350

*Contact factory for additional settings.

Cryogenic Economizers ECL Series

Application

The ECL series cryogenic economizers are primarily designed to utilize the gas pressure in a liquid cryogenic cylinder that would otherwise be lost to the atmosphere through the pressure relief valve. They may also be used in cryogenic lines, vaporizer and converter applications. They are especially useful in installations where space and cost limitations are important.

Features

- All parts are copper alloy (brass), PTFE and stainless steel—materials selected specifically for compatibility with cryogenic temperatures down to -320°F.
- Body and bonnet machined from solid brass bar stock.
- The ECL Series utilizes a stainless steel needle seat design that provides a very sensitive flow control at lower pressure settings.
- High and low pressure economizers are the same compact size—designed to fit in close quarters. The compact high pressure design has no loss of capacity.
- Interchangeable with existing cryogenic economizer units.
- Inlet filter helps prevent foreign materials from entering the economizer.
- Locknut is provided to maintain adjusting screw settings.
- Maximum inlet pressure of 550 PSIG.
- Cleaned for liquid oxygen service per CGA G-4.1
- 100% Factory Tested

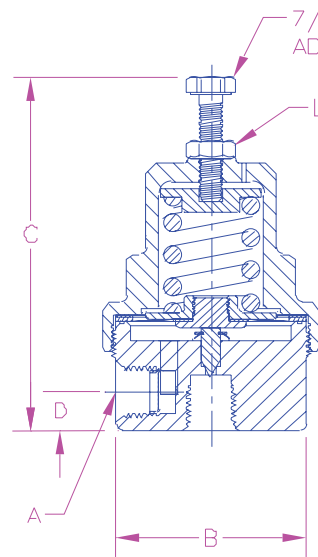

ECL Series

Materials

Body	Brass
Bonnet	Brass
Seat	Stainless Steel
Springs	Stainless Steel
Gasket	PTFE

Ordering Information

Part Number	Inlet / Outlet Connections (F.NPT) A	Width B	C	D	Pressure Setting (PSIG)	Operating Range (PSIG)
ECL22	1/4"	2 1/16"	3"	3/8"	22	10-150
ECL70					70	
ECL140					140	
ECL325					325	150-350

*Contact factory for additional settings.

RegO Combination Pressure Build/Economizer Regulator CBH & CBC Series

Application

Combines the function of RG and ECL Pressure Building and Economizer functions in one compact unit. Available in Chart and Taylor-Wharton piping geometries and a variety of pressure ratings.

Features

- All parts are copper alloy (brass, PTFE and stainless steel materials selected specifically for compatibility with cryogenic temperatures down to -320° F.
- Body and bonnet machined from solid brass bar stock.
- PTFE seat helps assure a positive shut-off at cryogenic temperatures down to -320° F.
- High and low pressure regulators/economizers are the same compact size designed to fit in close quarters.
- Interchangeable with existing cryogenic regulator units.
- Inlet filter helps prevent foreign material from entering the regulator.
- Locknut is provided to maintain adjusting screw setting.
- Maximum inlet pressure of 550 PSIG
- Cleaned for liquid oxygen service per CGA G-4.1
- 100% Factory Tested



CBH000125A

Materials

Body	Brass
Bonnet	Brass
Seat Disk	PTFE
Spring	Stainless Steel
Gasket	PTFE

CBH Series

CBC Series

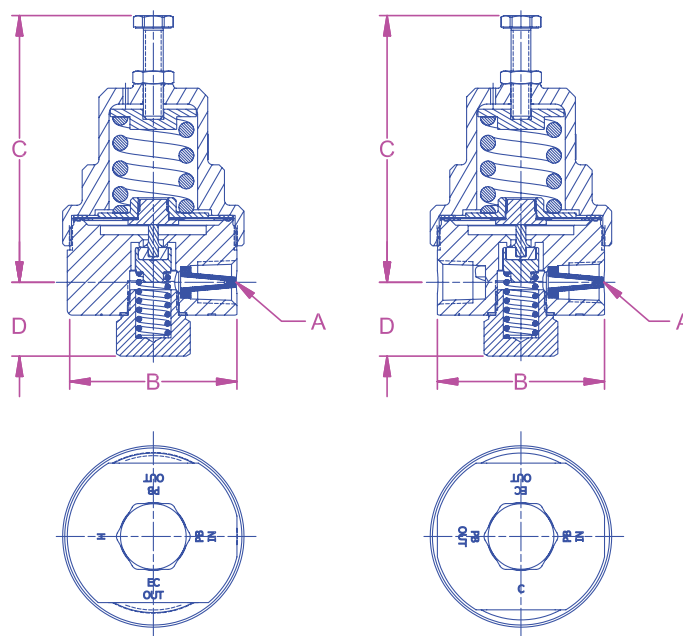

Ordering Information

Part Number	Inlet/Outlet Connections (F.NPT)	"A"	"B"	"C"	"D"	Factory Pressure Setting (PSIG)	Operating Range (PSIG)
CBH000125A	1/4"	1/4"	2 1/16"	3"	1"	125	25-250
CBH000300A						300	150-350
CBH000325A						325	150-350
CBC000125A						125	25-250
CBC000300A						300	150-350
CBC000325A						325	150-350

Cryogenic Liquid Cylinder Regulator LCR Series

Application

The REGO LCR Series regulator assembly controls the pressure from the gas use line discharge of any liquid cylinder with a flow capacity at least double the vaporization capacity of the cylinder vaporization coil. For use with oxygen, nitrogen, argon, or carbon dioxide liquid cylinders.

Features

- All parts are copper alloy (brass), PTFE and stainless steel materials selected specifically for compatibility with cryogenic temperatures down to -320°F.
- PTFE seat helps assure a positive shut-off at cryogenic temperatures down to -320°F.
- Easy adjusting screw to maintain pressure setting
- 100% Factory tested
- CGA fitting inlet connection for ready hook-up and ¼" F. NPT outlet.
- Pressure gauge for deliver pressure ranges available.
- Two delivery pressure ranges available.
- Clean for use in Oxygen per CGA G-4.1
- Temperature range -320°F (-196°C) to + 165°F (74°C)
- Maximum inlet pressure 550 PSI
- Inlet filter helps prevent foreign material from entering the regulator.

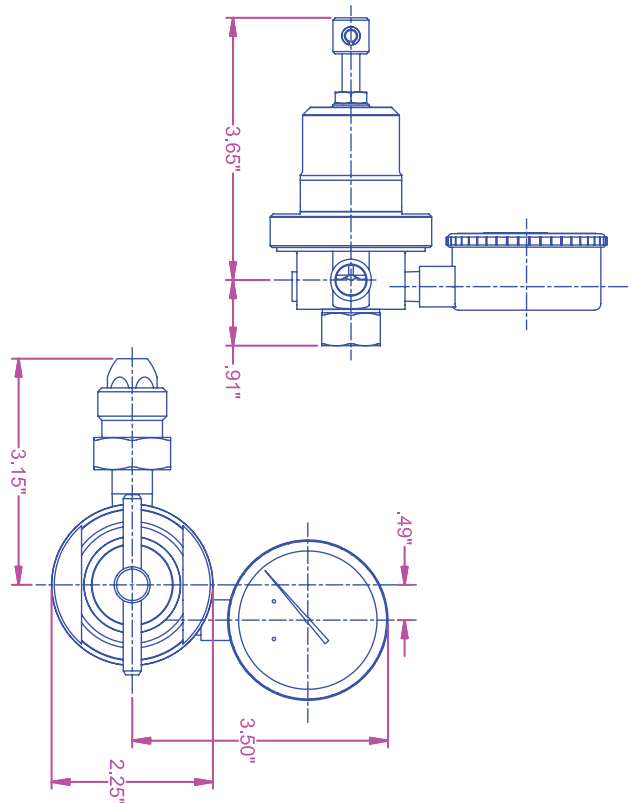

Materials

Body & Bonnet.....	Brass
Seat Retainer.....	Brass
Seat	PTFE
Spring & Nut	Stainless Steel
Diaphragm Gasket.....	PTFE
Diaphragm	Bronze
Backcap Gasket	Copper

Ordering Information

Part Number	Gas	Liquid Cylinder Connection	Delivery Pressure Range
LCR200A580	Nitrogen/Argon	CGA 580	25 to 250 psig
LCR200A540	Oxygen	CGA 540	25 to 250 psig
LCR200A320	Carbon Dioxide	CGA 320	25 to 250 psig
LCR350A580	Nitrogen/Argon	CGA 580	100 to 350 psig
LCR350A540	Oxygen	CGA 540	100 to 350 psig
LCR350A320	Carbon Dioxide	CGA 320	100 to 350 psig

RegO "NR" Series Noise Reduction Relief Valve

Application

Designed especially for indoor applications such as laboratories where relief valve discharge noise is an issue. RegO's NR series PRV provides excellent flow characteristics with a 50% reduction in outlet noise related to valve relief.

Features

- Packaged and cleaned for oxygen service per CGA G-4.1
- Bubble tight at 95% of set pressure
- 100% factory tested
- Repeatable performance
- Temperature range -320° to +165° F

Materials

Spring Steel
 Gasket PTFE
 Body Brass

WARNING: Inspection and maintenance of pressure relief valves is very important. Failure to properly inspect and maintain pressure relief valves could result in personal injuries or property damage. The useful safe service life of a pressure relief valve may be significantly affected by the service environment.

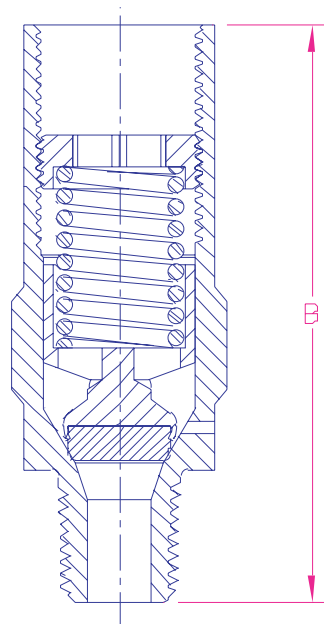
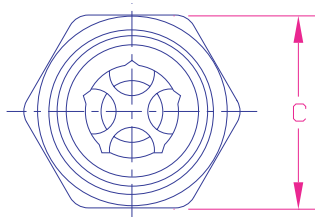

Ordering Information

Part Number	Seat Material	Inlet Connections (F.NPT)	"B"	"C"	Orifice Size In	Factory Pressure Setting (PSIG)	Pipe-Away Adapter
NR009432F022	Fluorosilicone	1/4"	2.60"	7/8"	.062	22	B-9412-2
NR009432F050						50	
NR009432F100						100	
NR009432T230	230						
NR009432T250	250						
NR009432T300	300						
NR009432T350	350						
NR009432T360	360						

Relief Valves for Gas & Cryogenic Systems

9400 Series Brass or Stainless Steel, Non-ASME

Application

These relief valves are specifically designed for thermal safety relief applications and cryogenic liquid containers.

Features

- All valves are cleaned and packaged for oxygen service per CGA G-4.1.
- Bubble tight at 95% of set pressure.
- Easy to read color coded psig / bar labels.
- Adapters provide standard pipe thread connections for venting gas to the outdoors.
- Repeatable performance.
- 100% factory tested.
- Temperatures Range -320° to +165° F.

Materials SS Style

Body	Stainless Steel
Spring	Stainless Steel
Seat Retainer.....	Stainless Steel
Adjusting Screw.....	Stainless Steel
Pipe-Away Adapter	Stainless Steel

Materials PRV and B-Style

Body	Brass
Spring	Stainless Steel
Seat Retainer.....	Brass
Adjusting Screw.....	Brass
Pipe-Away Adapter	Brass

Flow Performance

- PRV and SS style flow at 0.783 SCFM Air/PSIA at 110% of set pressure.
- B-9425N has a flow of 6.7 SCFM Air/PSIA at 120% of set pressure.
- B-9426N has a flow of 11.0 SCFM Air/PSIA at 120% of set pressure

Seat Material Option

F for Fluorosilicone for PRV and SS styles for 15-139psi.
 T for PTFE for PRV and SS styles for 140-600psi
 N for B-9425 and B-9426, Fluorosilicone seat, all set pressures.

Drain Hole Option

Relief valves without pipeaway typically provided with drain holes, leave blank. **P** - for relief valves without drain hole, for example PRV9432TP350

WARNING: Inspection and maintenance of pressure relief valves is very important. Failure to properly inspect and maintain pressure relief valves could result in personal injuries or property damage. The useful safe service life of a pressure relief valve may be significantly affected by the service environment.

Ordering Information

Ordering Information

Fill in the blanks with options below.

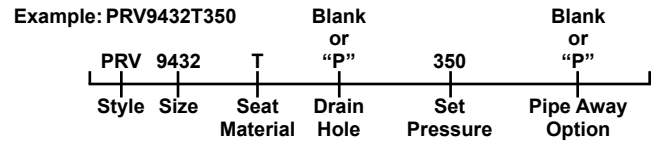

This example part number indicates a 1/4" M.NPT relief valve with PTFE seat, set at 350 PSIG with drain hole and no pipe away adapter.

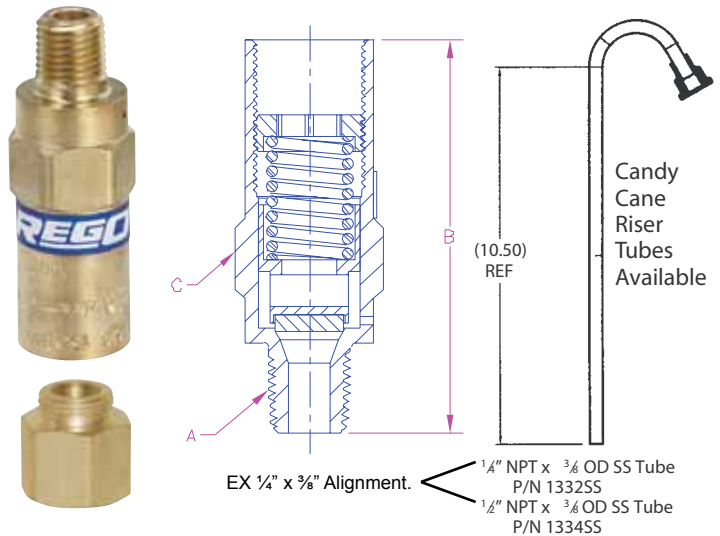

Set Pressure

Specify set pressure within range specified for style and size. The B-9425 & B-9426N are available in select settings only. Special order.

Pipe Away Option

P Pipeaway included and attached, No drain hole in relief valve.
 For example PRV9432TP350
 Leave blank for relief valve without pipe-away attached.
 For example PRV9432TP 350.

For easy identification, the following standard settings have color coded labels for all PRV and SS Style sizes and settings marked in PSIG and bar:

Color Identification

22 psig	yellow	230 psig	blue
35 psig	purple	350 psig	orange
50 psig	white	450 psig	pink
100 psig	gray	500 psig	light blue
150 psig	red		

Style	Size	Inlet M.NPT A	Body and Valve Material	Pressure Setting Range PSIG	Height B	Wrenching Hex C	Orifice Size Sq. Inch	Pipe-Away Adapter P/N	Pipe-Away Outlet F.N.P.T.
PRV	9432	1/4"	Brass	17-600	2.6"	7/8"	.062	B-9412-2	3/8"
SS	9432	1/4"	Stainless Steel	17-600	2.6"	7/8"	.062	SS-9412-4	1/2"
PRV	9433	3/8"	Brass	17-600	2.6"	7/8"	.062	B-9412-2	3/8"
SS	9433	3/8"	Stainless Steel	17-600	2.6"	7/8"	.062	SS-9412-4	1/2"
PRV	9434	1/2"	Brass	17-600	2.8"	7/8"	.062	B-9412-4	1/2"
SS	9434	1/2"	Stainless Steel	17-600	2.8"	7/8"	.062	SS-9412-4	1/2"
B-	9425	3/4"	Brass	50-300	3.4"	1 3/4"	.43	B-3131-10	1"
B-	9426	1"	Brass	100-300	5.5"	2 3/8"	.62	B-3132-10	1 1/4"

ASME Relief Valves for Gas & Cryogenic Systems

PRV 19430 Series Brass Relief Valves & PRV 29430 Series Stainless Steel Relief Valves

Application

These relief valves are designed for oxygen and other industrial gases and for cryogenic service. Apply on piping systems, liquid cylinders or mini-bulk cryogenic containers where an ASME relief valve is desired.

Features

- A.S.M.E. rated, National Board Certified.
- Bubble tight at 95% of set pressure.
- Full flow at 110% at set pressure.
- Repeatable performance.
- 100% factory tested.
- Temperatures Range -320° F to 165° F.
- Cleaned and packaged for oxygen service per CGA G-4.1.

Materials

Spring Stainless Steel
Body, valve parts, and seat as shown in part number

Flow Performance

PRV19430 and PRV29430 Series: 0.783 SCFM of air per psia of flow pressure. Flow pressure per ASME is 10% above set pressure.

Ordering Information

Fill in the blanks with options below.

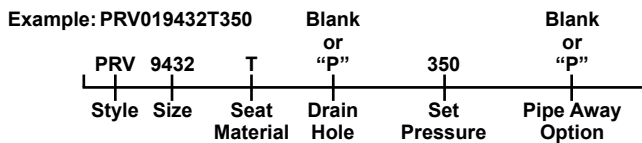

Material and Inlet Part Number Options

19432 for Brass 1/4", 19433 for Brass 3/8", 19434 for Brass 1/2",
29432 for SS 1/4", 29433 for SS 3/8", 29434 for SS 1/2".

Seat Material

F for Fluorosilicone for 90 to 139 psig set.
T for PTFE for 140-600 psig

Drain Hole

Leave blank for relief with drain hole. Insert P if no drain hole.

Set Pressure

Enter number for set pressure in PSIG from 90 to 600.

Ordering Information

Part Number	Inlet A	Height B	Wrenching Hex C	Orifice Size
PRV 19432 and PRV29432	1/4"	2.6	7/8"	.062 sq. inch
PRV 19433 and PRV29433	3/8"	2.6	7/8"	.062 sq. inch
PRV 19434 and PRV29434	1/2"	2.8	7/8"	.062 sq. inch



1943 Series

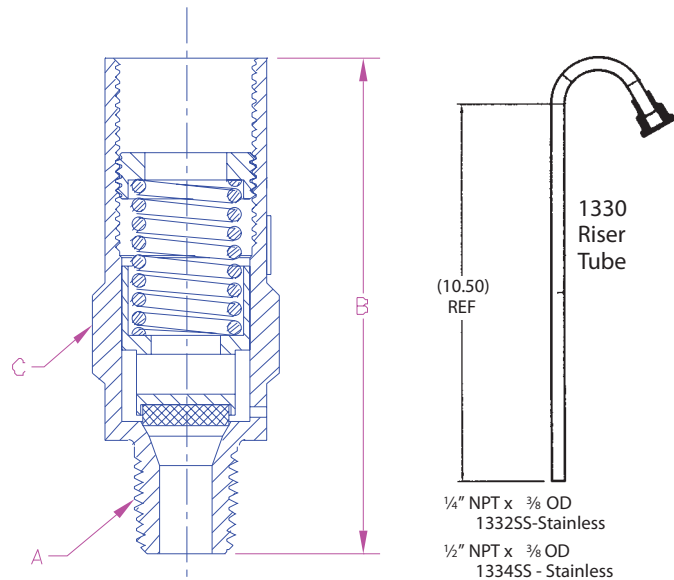

WARNING: Inspection and maintenance of pressure relief valves is very important. Failure to properly inspect and maintain pressure relief valves could result in personal injuries or property damage. The useful safe service life of a pressure relief valve may be significantly affected by the service environment.

ASME Carbon Dioxide Relief Valves UA3149A Series

Application

The UA3149A series “pop-type” relief valves are especially designed for use as a secondary relief valve in carbon dioxide transports and stationary storage tanks. The relief valve is designed to protect the tank from excessive over pressure in the event of fire or other emergencies. A small throttling-type primary relief valve must also be provided to control boil-off and maintain tank pressure. Provisions must be made to prevent the accumulation and build-up of water and foreign material in the valve.

Features

- “Pop-type” design permits the relief valve to open slightly to relieve moderately excessive pressures.
- Relief valve “pops” open to full discharge capacity when pressure exceeds a predetermined point.
- 100% Factory Tested

Materials

Body Steel and Ductile Iron
 Liner..... Stainless Steel
 Seat Insert Stainless Steel
 Spring Guide..... Brass
 Adjusting Screw..... Ductile Iron
 Seat Disc Urethane Compound
 Spring Corrosion Resistant Steel

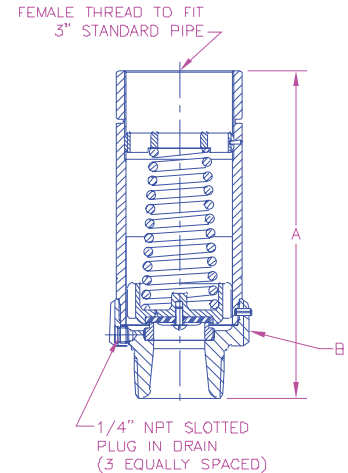

Ordering Information

Part Number	Pressure Setting (PSI)	Flow Capacity (SCFM/Air)	Inlet Connection (M.NPT)	Height A	Wrenching Hex B
UA3149A303	303	9,805*	2½"	10½"	4 ⅛"
UA3149A330	330	10,188*			
UA3149A358	358	11,601*			

*Capacity certified by National Board of Boiler and Pressure Vessel Inspectors at 10% above set pressure.

Brass Pipe Caps

Application

For capping cryogenic tank piping or gas pipelines.

Features

- Machined from brass.
- For 600 psig maximum working pressure service.
- Part number stamped on cap.
- Cleaned for oxygen per CGA G-4.1.

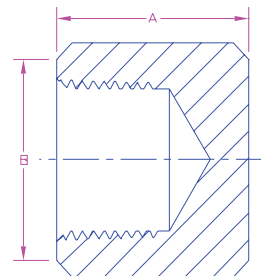

Ordering Information

Part Number	Thread Connections	Dim. A	Dim. B	Dim. C
CAP750	¾" Female NPT	1.250"	1.313"	1.313"
CAP1000	1" Female NPT	1.500"	1.750"	1.750"
CAP1500	1 ½" Female NPT	1.750"	2.375"	2.375"
CAP2000	2" Female NPT	2.000"	3.250"	3.250"

ASME Relief Valves for Gases & Cryogenic Systems B-19434B Series & C-19434B Series

Application

The B-19434B Series relief valves are suitable for use with oxygen and non corrosive gases.

The C-19434B series relief valves are designed for use in carbon dioxide service.

Features

- Both designs permit the valve to open slightly to relieve moderately excessive pressure.
- When the pressure increases beyond a predetermined point, the valve opens to its full discharge capacity in order to quickly reduce excess pressure.
- Pipe-away adapter for venting gas to the outdoors is available.
- A.S.M.E. rated. NB Certified.
- B-19434-B Series are cleaned for use in oxygen per CGA G-4.1.

Materials

Body	Brass
Spring	Stainless Steel
Seat Retainer.....	Brass
Seat Disc (B-19434B Series).....	Fluorosilicone
Seat Disc (C-19434B Series)	EPDM Synthetic Rubber
Pipe-Away Adapter	Brass

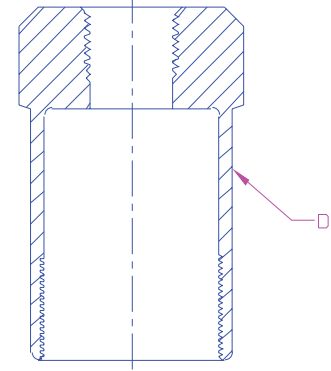

B-19434B Series

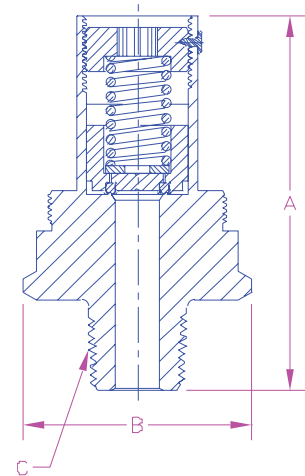

Ordering Information

Part Number	Pressure Setting (PSIG)	ASME Relief Capacity (CFM/Air)	Height A	Width B	Inlet Connection (M.NPT) C	Pipe-Away Adapter Part Number D
B-19434B235	235	476	2 ¹⁵ / ₁₆ "	1 ¹ / ₄ "	1/2"	*B-19434-5 1/2" F.NPT Outlet
B-19434B250	250	505				
B-19434B300	300	601				
B-19434B350	350	691				
B-19434B375	375	736				
C-19434B235	235	476				
C-19434B250	250	505				
C-19434B280	280	555				
C-19434B300	300	601				
C-19434B350	350	691				
C-19434B375	375	736				

* Pipe Away Adapter is sold separately.

** Contact factory for additional settings.

Heavy Duty Brass Final Line Pressure Regulator

BR-1780 Series

Application

The BR-1780 Series Regulators are designed for final line pressure regulation on medical oxygen systems. They are equally suitable for a variety of gases in medical or industrial applications. The BR-1780 Series Regulators have a balanced seat, are constructed with oxygen compatible materials, and offer a tamper resistant adjustment screw cap. Flow performance is impressive as well offering up to 30,000 SCFH for the 3/4" and 1" model and up to 20,000 SCFH for the 1/2" model.

Features

- Maintains a steady downstream pressure across a range of inlet pressure commonly provided by a cryogenic bulk tank.
- Large seat and diaphragm areas provide high capacity with sensitive control of delivery pressure with low falloff.
- Two 1/4" FNPT delivery pressure gauge ports are located (plugged) on each side of the valve.
- Two bonnet drain/vent holes to allow for different mounting orientation.
- Bonnet cap covering adjusting screw for tamper protection.
- Maximum inlet pressure is 435 psig.
- Available in four delivery pressure ranges.
- Temperature range: -40° F to +165° F.
- Cleaned per CGA G-4.1 for oxygen service.
- 100% Factory Tested

Materials

Body Forged Brass
Bonnet Cast bronze for BR-1786/1788
 Forged brass for BR-1784
Diaphragm Nitrile with PTFE liner
Springs, fasteners, and adjusting screw Stainless Steel
Other valve parts Brass
Seat Disc & O-Rings Viton is standard

For Carbon Dioxide and Nitrous Oxide Service: Specify EPDM material for seat disc and O-Rings, add "E" to end of part number.

Maintenance and Options Kits

Regulator Models	BR1784	BR1786	BR1788
Repair Kit Part Number	BR1784-80	BR1786-80	BR1788-80
Spring Kit Part Numbers:			
"A" spring 5 -55 psig	BR1784-7SKA	BR1786-7SKA	BR1788-7SKA
"B" spring 40-110 psig	BR1784-7SKB	BR1786-7SKB	BR1788-7SKB
"C" spring 100-200 psig	BR1784-7SKC	BR1786-7SKC	BR1788-7SKC
"D" spring 175-275 psig	BR1784-7SKD	BR1786-7SKD	BR1788-7SKD
T-Handle Screw Option Kit	BR1784ST	BR1786ST	BR1788ST



BR-1784



BR1786 and BR1788

Heavy Duty Brass Final Line Pressure Regulator BR-1780 Series

Flow Performance

See the Rego Flow Performance Curves section of the catalog for more detailed flow curves.

BR-1786 & BR-1788

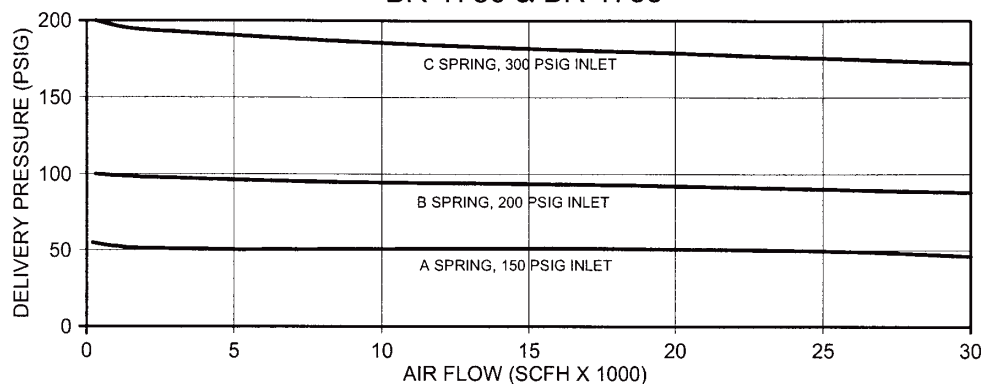

BR-1784

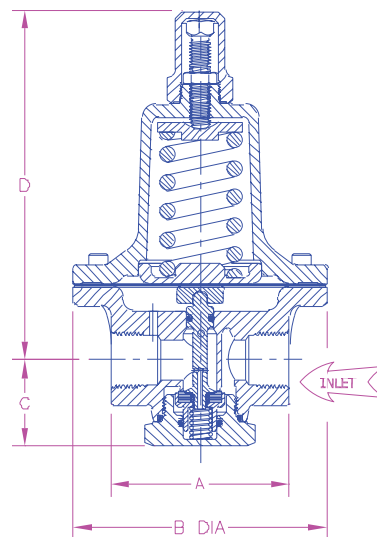
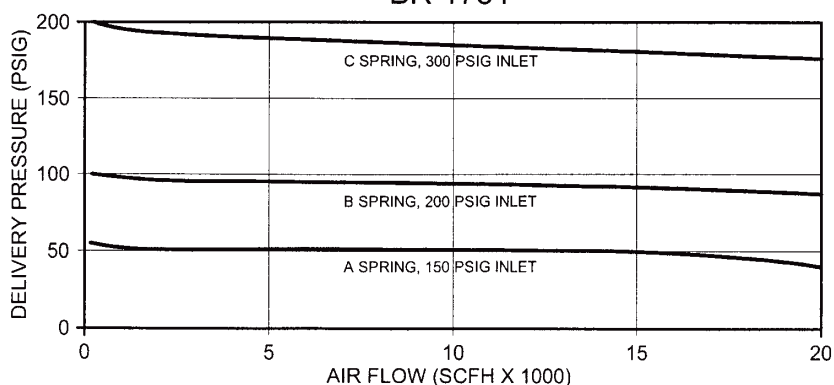

Dimensions

The BR-1780 Series Regulators have inlet and outlet connection dimensions similar to the popular 1680 Series aluminum regulators. This means that you can replace the respective size 1680 Series regulator with the new BR-1780 Series regulator and have the improved performance and premium features available on the BR-1780 Series

For Carbon Dioxide or Nitrous Oxide Service, add "E" to end of part number.

Ordering Information

Part Number	Delivery Pressure Range	Pressure Gauge*		Inlet & Outlet (F.N.P.T.)	Dimensions				C _v
		Range (PSI)	P/N		"A"	"B"	"C"	"D"	
BR-1784A	5-55 psig	1-100	1286	1/2"	2.82"	3.62"	1.38"	5.21"	3.1
BR-1784B	40-110 psig	1-200	S1679						
BR-1784C	100-200 psig	1-400	15578						
BR-1784D	175-300 psig								
BR-1786A	5-55 psig	1-100	1286	3/4"	3.31"	4.69"	1.60"	6.46"	4.8
BR-1786B	40-110 psig	1-200	S1679						
BR-1786C	100-200 psig	1-400	15578						
BR-1786D	175-275 psig								
BR-1788A	5-55 psig	1-100	1286	1"	3.31"	4.69"	1.60"	6.46"	5.5
BR-1788B	40-110 psig	1-200	S1679						
BR-1788C	100-200 psig	1-400	15578						
BR-1788D	175-275 psig								

*Regulator sold without gauge. Order gauge separately.

Heavy Duty Gas Line Regulator 1780 Series

Application

The 1780 Series Regulators are designed for final line pressure regulation on gas distribution systems. They are suitable for a variety of gases in medical or industrial applications. The 1780 Series Regulators have a balanced seat, are constructed with oxygen compatible materials, and have the same valve design, brass body, and internal parts as the premium BR-1780 Series. Flow performance is likewise equal to the BR-1780 Series.

Features

- Maintains a steady downstream pressure across a range of inlet pressure commonly provided by a cryogenic bulk tank.
- Large seat and diaphragm areas provide high capacity with sensitive control of delivery pressure with low falloff.
- Two 1/4" FNPT delivery pressure gauge ports are located (plugged) on each side of the valve.
- Two bonnet drain/vent holes to allow for different mounting orientation.
- T-handle adjusting screw.
- Maximum inlet pressure is 435 psig.
- Available in four delivery pressure ranges.
- Temperature range: -40° F to +165 F.
- Cleaned per CGA G-4.1 for oxygen service.
- 100% Factory Tested

Materials

Body Forged Brass
 Bonnet Nickel Plated Aluminum
 Diaphragm Nitrile with PTFE liner
 Springs and Fasteners Stainless Steel
 Other valve parts Brass
 Seat Disc & O-Rings Viton is standard

For Carbon Dioxide or Nitrous Oxide service: Specify EPDM material for seat disc and O-rings, add "E" to end of part number.

Dimensions

The 1780 Series Regulators have inlet and outlet connection dimensions similar to the popular 1680 Series aluminum regulators. This means that you can replace the respective size 1680 Series regulator with the new 1780 Series regulator and have the improved balanced seat performance.



1780 Series

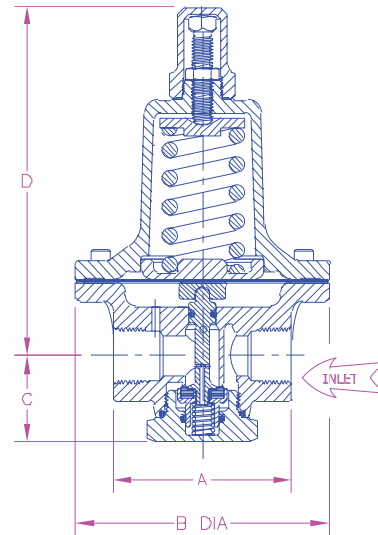

Ordering Information

Part Number	Delivery Pressure Range	Pressure Gauge*		Inlet & Outlet (F.N.P.T.)	Dimensions				C _v
		Range (PSI)	P/N		"A"	"B"	"C"	"D"	
1784A	5-55 psig	1-100	1286	1/2"	2.82"	3.62"	1.38"	5.47"	3.1
1784B	40-110 psig	1-200	S1679						
1784C	100-200 psig	1-400	15578						
1784D	175-300 psig								
1786A	5-55 psig	1-100	1286	3/4"	3.31"	4.69"	1.60"	6.84"	4.8
1786B	40-110 psig	1-200	S1679						
1786C	100-200 psig	1-400	15578						
1786D	175-275 psig								
1788A	5-55 psig	1-100	1286	1"	3.31"	4.69"	1.60"	6.84"	5.5
1788B	40-110 psig	1-200	S1679						
1788C	100-200 psig	1-400	15578						
1788D	175-275 psig								

*Regulator sold without gauge. Order gauge separately.

Heavy Duty Line Regulators Performance Curves

1780 Series & BR-1780 Series

"A" spring range 5 - 55 psig

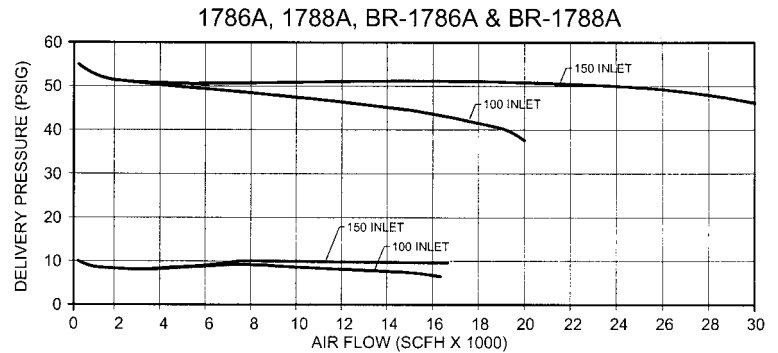
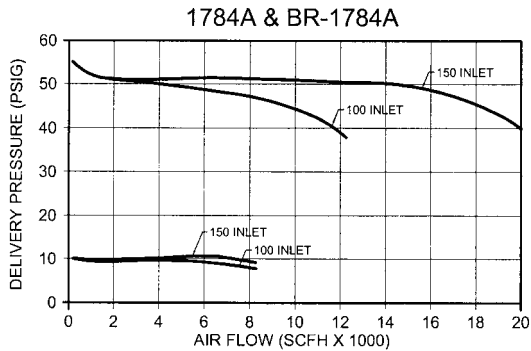

"B" spring range 40 - 110 psig

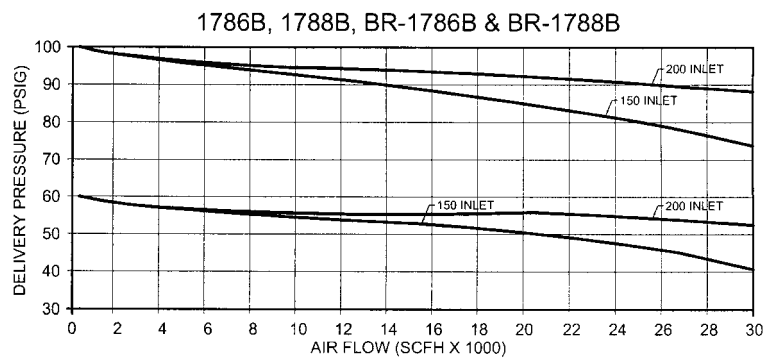
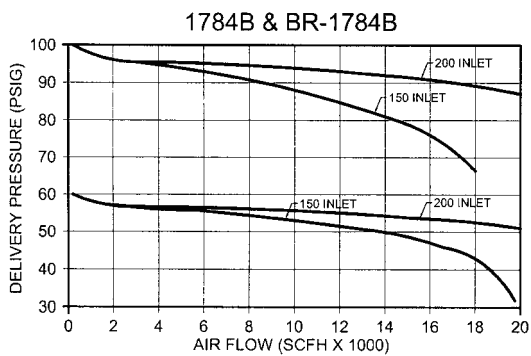

"C" spring range 100 - 200 psig

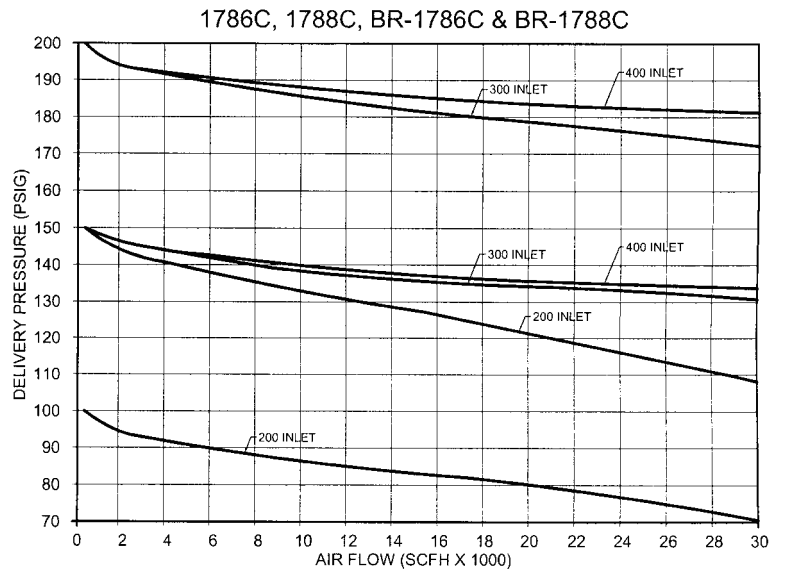
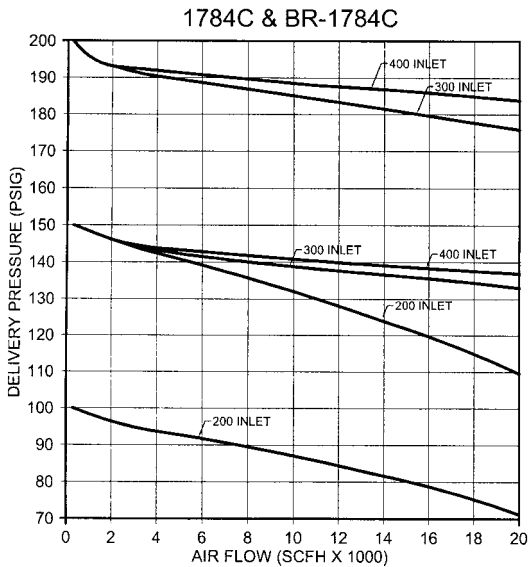

Gas Conversion Table

Service	Multiply Air Capacity By:
Acetylene (15 psi max.)	1.06
Argon	0.85
Carbon Dioxide	0.81

Service	Multiply Air Capacity By:
Fuel Gases	0.86
Helium	2.69
Hydrogen	3.79
Nitrogen	1.02

Service	Multiply Air Capacity By:
Nitrous Oxide	0.81
Oxygen	0.95

Automatic Changeover Regulators M2523HP Series

Application

The M2523HP series automatic changeover regulators are designed especially for use in systems where a reserve cylinder is used to provide a continuous, uninterrupted supply of gas. These regulators are suitable for use with carbon dioxide, hydrogen, oxygen, industrial air, nitrous oxide, nitrogen, helium and argon.

Features

- Automatically withdraws from reserve cylinder after exhausting the "service" cylinder.
- Cylinder pressure gauges let you know at a glance which cylinder is in use. There is no need to shutdown the system to replace empty cylinders.
- Nickel plated.
- 100% Factory Tested
- Porous bronze filters are installed in each inlet to minimize the entry of foreign particles.
- Back pressure check valves are installed in each inlet to help assure positive shut-off in case of reverse flow.
- Each unit comes complete with mounting bracket and a special delivery pressure adjustment wrench.
- Factory set at 50 PSIG on service side. CO₂ and N₂O regulators are factory set at 100 PSIG on service side.

Materials

Body	Brass
Bonnet	Brass
Seat Disc (all gases except CO ₂)	Viton
Seat Disc (CO ₂ Only)	Butyl Rubber
Diaphragm (all gases except CO ₂)	Neoprene
Diaphragm (CO ₂ Only)	Buna N
Handle	Aluminum
Bonnet Spring	Steel
Backcap Spring	Stainless Steel

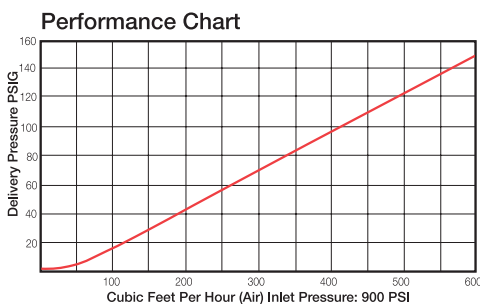
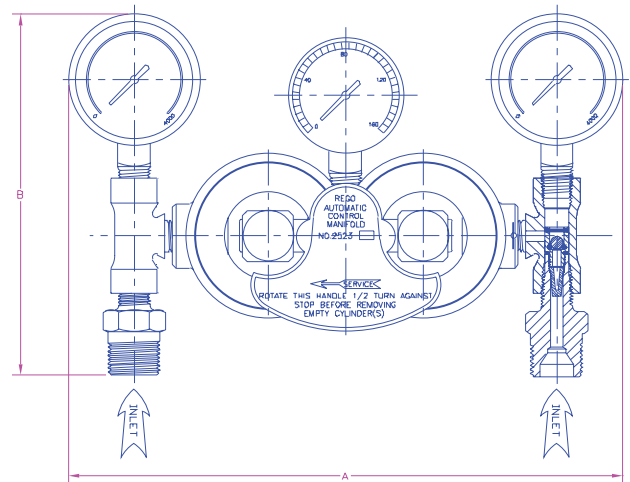

Source	Multiply
Carbon Dioxide	.81
Nitrogen	1.02
Nitrous Oxide	.81
Argon	.85
Oxygen	.95
Helium	2.69
Hydrogen	3.79

Ordering Information

Part Number	Gas Service	CGA Inlet Connection	Outlet Connection	Width A	Height B	Maximum Inlet Pressure (PSIG)	Delivery Pressure Range (PSIG)	Accessory Regulators*
M2523HP320	Carbon Dioxide	320	1/4" F.NPT	7 3/4"	5 1/8"	1800	30-130	BR-1784E, 1784E C-1682 M Series
M2523HP326	Nitrous Oxide	326						
M2523HP350	Hydrogen	350						
M2523HP540	Oxygen	540				3000		1784 Series 1682 M Series BR 1784 Series
M2523HP580	Nitrogen, Argon, Helium	580						
M2523HP590	Industrial Air	590						

* Can be used downside of the M2523HP as a final line pressure regulator. See pages 27 through 30 and page 33.

Low Pressure Line Regulators 4403 Series

Application

The 4403 series regulators provide very sensitive control of a variety of gases at low pressures. The large molded diaphragm assures responsive regulation with inlet pressures up to 250 PSI.

Features

- Large molded diaphragm provides highly sensitive and accurate low pressure control.
- Zinc body and bonnet resist corrosion and provide longer life.
- Teflon seat disc, teflon faced diaphragms, and stainless steel nozzles make the T4403J regulators compatible with a variety of gases.
- LV4403C2H42 features integral relief valve set at 3 psig.
- Adjusting screw is concealed by a plastic cap which helps prevent pressure adjustments by unauthorized personnel.
- Working temperature range is -40°F to +165°F.
- Not suitable for oxygen applications

Materials

Body	Zinc
Bonnet	Zinc
Diaphragm	T4403J, 4403W, S4, T4, U4 Teflon Faced Buna N
4403WP4, R4	Buna N
(LV4403C)	Integrated Fabric and Synthetic Rubber
Spring	Steel
Seat (T4403J)	PTFE
(4403W) (LV4403C)	Buna N
Nozzle (T4403J)	Stainless Steel
(4403W, LV4403C)	Brass

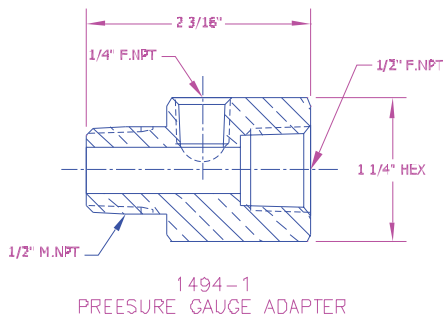

4403

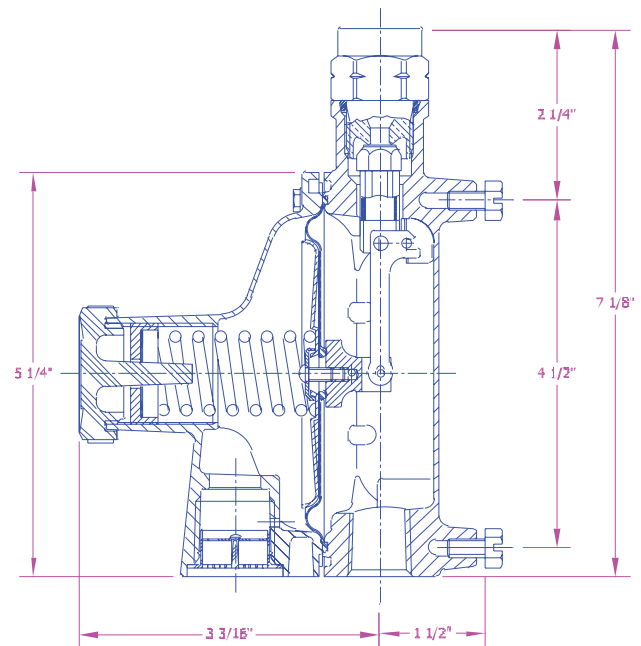

Ordering Information

Part Number	Inlet Connection	Outlet Connection	Factory Delivery Pressure*	Delivery Adjustment Range	Relief Setting
4403W-P4	1/2" F.NPT	1/2" F.NPT	6" w.c.	3.5 - 6" w.c.	None
4403W-R4			25" w.c.	15 - 28" w.c.	
4403W-S4			5 PSIG	1 - 5 PSIG	
4403W-T4			10 PSIG	5 - 10 PSIG	
4403W-U4			15 PSIG	10 - 15 PSIG	
LV4403C2H42	1/4" F.NPT	1/2" F.NPT	1.5 PSIG	1.5 PSIG	3 PSIG ± 20%
T4403JS2			5 PSIG	1 - 5 PSIG	None
T4403JT2			10 PSIG	5 - 10 PSIG	

* Based on 50 PSIG inlet pressure. LV4403C2H42 based on 100 PSIG inlet pressure.

Aluminum Pressure Regulators 1682M Series & C-1682M Series

Application

The 1682M Series Regulators are designed primarily for second stage regulation of a variety of gases in industrial piping systems, hospital piping systems and manifold systems.

The C-1682M Series is specifically designed for use with Carbon Dioxide.

Features

- Maximum inlet pressure is 400 PSIG.
- Two 1/4" F.NPT gauge ports are located 180° apart to allow for gauge mounting in the most convenient positions.
- Each 1680M Series regulator is cleaned and packaged for oxygen per CGA G-4.1.
- 100% Factory Tested
- T-handle adjusting screw.
- Available in three delivery pressure ranges.
- Temperature Range: -40° F to +165°F

Materials

Body Forged Aluminum
 Bonnet Cast Aluminum
 Seat Disc (1682M) Neoprene
 Seat Disc (C-1682M) EPDM
 Diaphragm (1682M) Neoprene
 Diaphragm (C-1682M) EPDM



C-1682M

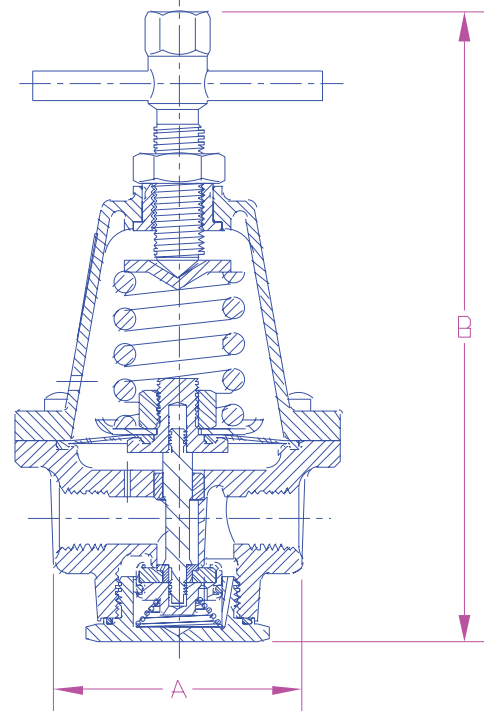

1682M SERIES REGULATOR FLOW PERFORMANCE

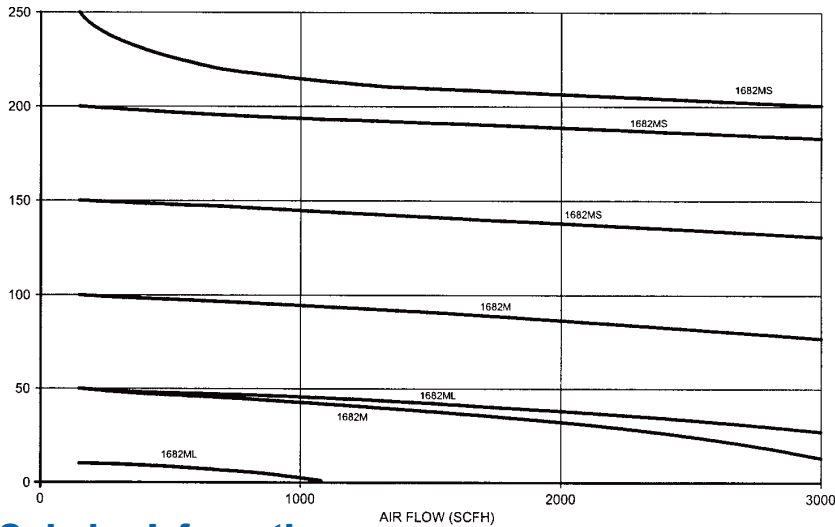

Ordering Information

Part Number		Delivery Pressure Range (PSI)	Pressure Gauge		Inlet & Outlet Connection (F.NPT)	Width A	Maximum Height B
			Range (PSI)	Part Number			
1682ML	C-1682ML	5-50	*	*	1/4"	2 ³ / ₁₆ "	4 1/8"
1682MLG	C-1682MLG		1-100	1286			
1682M	C-1682M	50-125	*	*			
1682MG	C-1682MG		1-200	S1679			
1682MS	C-1682MS	100-250	*	*			
1682MSG	C-1682MSG		1-400	15578			

* Pressure gauge not included.

Inertrol Outfits

4286 Series, 4289 Series & 4291 Series

Application

The 4286, 4289, and 4291 series inertrol outfits are three stage nitrogen regulators especially designed to maintain oilfilled transformer atmospheres at 0.5 PSIG. Each inertrol outfit consists of a two-stage regulator connected in series to a highly sensitive single-stage regulator which maintains the 0.5 PSIG pressure. A built-in pressure relief valve in the third stage regulator helps protect against over-pressurization of the system.

These inertrol units are designed for oil-filled transformers manufactured by ABB, Inc., General Electric, and Cooper Power. Some outfits are equipped with an alarm switch that activates a customer equipped warning device should the cylinder pressure drop below 300 PSIG.

Features

- Heavy duty brass and aluminum construction resists corrosion and provides for longer life.
- The 4289 series incorporates a special by-pass valve to allow for quick filling of the transformer.
- Hidden pressure adjusting screw helps protect against tampering by unauthorized personnel.
- Large diameter diaphragm in the third-stage regulator provides for sensitive and precise control of the gas flow.
- Maximum inlet pressure - 3000 PSIG.

Materials

Two-Stage Regulator:

Body	Brass
Bonnet	Brass
Diaphragms	Synthetic Rubber
1st Stage Seat Disc	Nylon
2nd Stage Seat Disc	Neoprene

Third-Stage Regulator:

Body	Zinc
Bonnet	Zinc
Diaphragm	Buna N
Seat Disc	Buna N

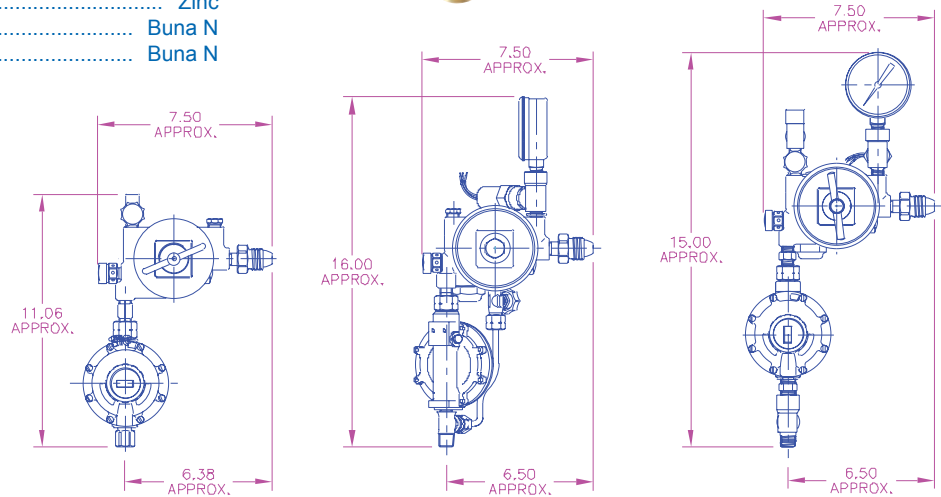

Ordering Information

Part Number	Gas Service	Inlet	Outlet	Two Stage Regulator Part number	Third Stage Regulator Part Number	Alarm Gauge	Transformer Manufacturer
4286A580	Nitrogen	CGA580	1/8" NPT	4286A-2NW	4286-10-8	None	ABB, Inc.
4289AG			9/16" -18 L.H.	4289A-2G	4289-10	4285-9B	General Electric
4289G						None	
4291A			3/8" NPT	4291B-2	4286-10-8	4285-9B	Cooper Power

Low Pressure Regulators 4286-10 Series & 4289-10 Series

Application

The 4286 and 4289 series inertrol third-stage low pressure regulators are designed especially for secondary regulation of gaseous nitrogen on electrical transformer systems.

These regulators are factory preset at 14" to 15" water column delivery pressure with an inlet pressure of 5 to 10 PSIG.

Features

- Large diaphragm allows for highly sensitive and accurate low pressure control.
- Incorporates integral relief valves (except on 4289-10).
- Zinc body and bonnet resist corrosion and provide longer life.
- Adjusting screw is concealed by a cap to help prevent against tampering by unauthorized personnel.
- Operating temperature range is -40°F to +160°F.

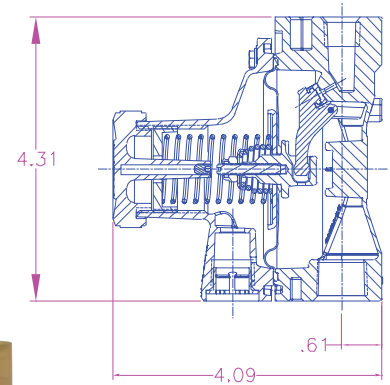

4286-10

Materials

Body Zinc
 Bonnet Zinc
 Diaphragm Buna N
 Seat Disc Buna N
 Spring Steel

Ordering Information

Part Number	Inlet (NPT)	Outlet (NPT)	Delivery Pressure Setting	Relief Valve Setting
LV4286-10-5	1/4"	3/8"	14"-15" w. c.	5 PSIG
LV4286-10-8				8 PSIG
4289-10				None

Alarm Gauges 4285-9B

Application

The 4285-9B inertrol alarm gauges are designed to alert the user when pressure has fluctuated ±90 PSIG from the 300PSIG factory setting. Under these conditions, electrical contacts in the switch will close and set off a user-furnished alarm system.

Features

- Solid brass gauge casing resists corrosion and provides for longer life.
- Equipped with a heavy-duty, 36" long, 3-wire electrical cable.
- Each gauge is factory pre-set at 300 PSIG, then sealed to help prevent against tampering once in service.
- Electrical circuit is rated for a maximum of 3 AMPS at 460 volts AC.

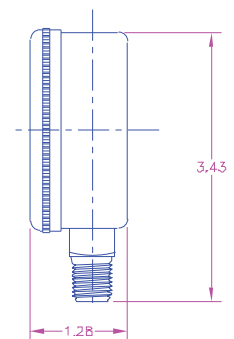

4285-9B

Materials

Gauge Casing Brass

Ordering Information

Part Number	Inlet M.NPT	Diameter	Pressure Range (PSIG)	Adjustable	Alarm Furnished
4285-9B	1/4"	2 1/2"	0 - 4000	No	None

Brass Pipe & Pipe Nipples

Heavy-duty, yellow brass pipe and pipe nipples are designed with a high quality, seamless thick wall construction. They are suitable for use in most industrial piping applications.

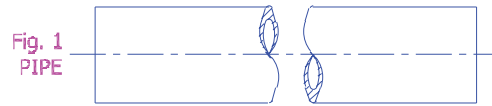

For the 1/2" I.D. pipe, the O.D. is 0.840".
For the 3/4" I.D. pipe, the O.D. is 1.050".

Ordering Information

Part Number	Figure	Inside Diameter	Inlet / Outlet Connections (M.NPT)	Length	Maximum Operating Pressure (PSIG)*
TNE1050-14400	1	1/2"	Not Available	12 Feet	3600
TNE1075-14400		3/4"			
1050-15	2	1/2"	1/2"	1 1/2"	
1050-20				2"	
1050-40				4"	
1050-60				6"	
1050-80				8"	
1075-20		3/4"	3/4"	2"	
1075-30				3"	
1075-40				4"	
1075-50				5"	
1075-60				6"	

Brass Elbows

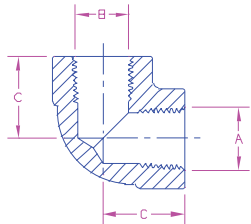

Fig. 1

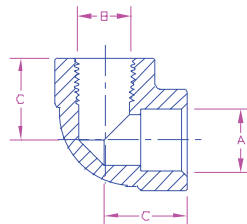

Fig. 2

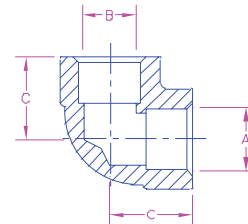

Fig. 3

Ordering Information

Part Number	Figure	A (Female)	B (Female)	C (Ref.)	Working Pressure PSIG*
1228-1	1	1/2" NPT	1/2" NPT	1 1/8"	3750
HP1228-1		3/4" NPT	3/4" NPT	1 1/2"	4500
1043				1 1/2"	4500
1228-2	2	1/2" NPT	.843-.847	1 1/8"	3750
HP1228-2		3/4" NPT	1.053-1.057	1 1/2"	4500
2223-2				1 1/8"	3750
1228-4	3	.843-.847	.843-.847	1 1/2"	6000
HP1228-4				1 1/2"	4500
2233-6		1.053-1.057	1.053-1.057	1 1/2"	4500

*Safety factor = 4:1

Brass Tees

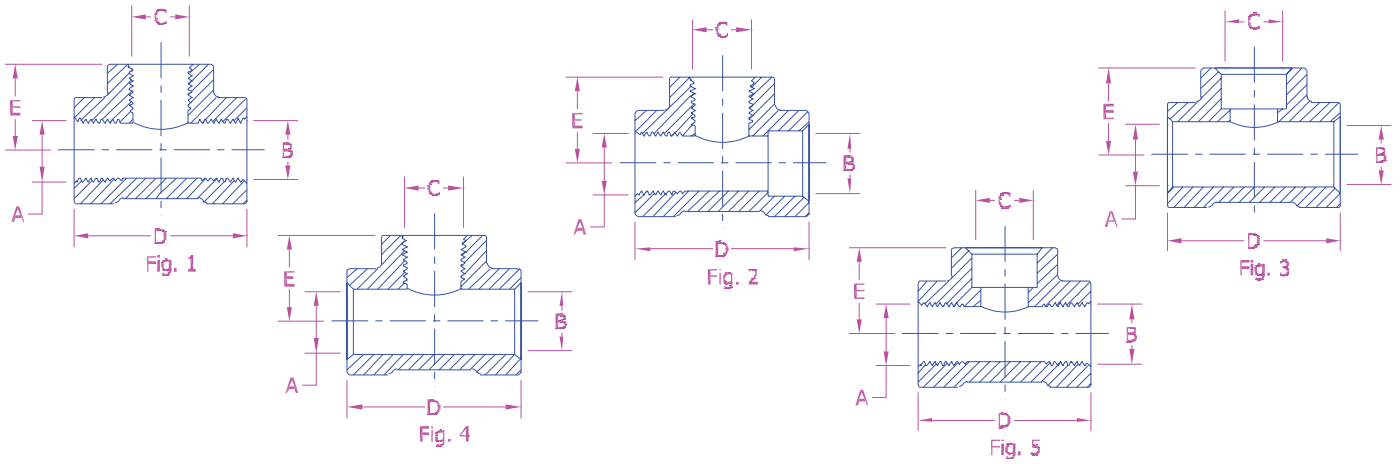

Ordering Information

Part Number	Figure	A (Female)	B (Female)	C (FEMALE)	D (Ref.)	e (Ref.)	Working Pressure PSIG*
1227-1	1	½" NPT	½" NPT	½" NPT	2¼"	1⅞"	3750
HP1227-1					3"	1½"	4500
1042-20		¾" NPT	¾" NPT	½" NPT	3"	1½"	4500
1042					¾" NPT	1½"	4500
1227-3	2	½" NPT	.843-.847	½" NPT	2¼"	1⅞"	3750
HP1227-3					3"	1½"	4500
4608-5		¾" NPT	1.053-1.057	¾" NPT	3"	1½"	4500
1227-28	3	.843-.847	.843-.847	.843-.847	2¼"	1⅞"	3750
HP1227-28					3"	1½"	6000
2118-2		1.053-1.057	1.053-1.057	1.053-1.057	3"	1½"	4500
1227-9	4	.843-.847	.843-.847	½" NPT	2¼"	1⅞"	3750
HP1227-9					3"	1½"	4500
2223-3		1.053-1.057	1.053-1.057	¾" NPT	3"	1½"	4500
HP1227-5	5	½" NPT	½" NPT	.843-.847	3"	1½"	4500
2222-1							

*Safety factor = 4:1

Brass Crosses

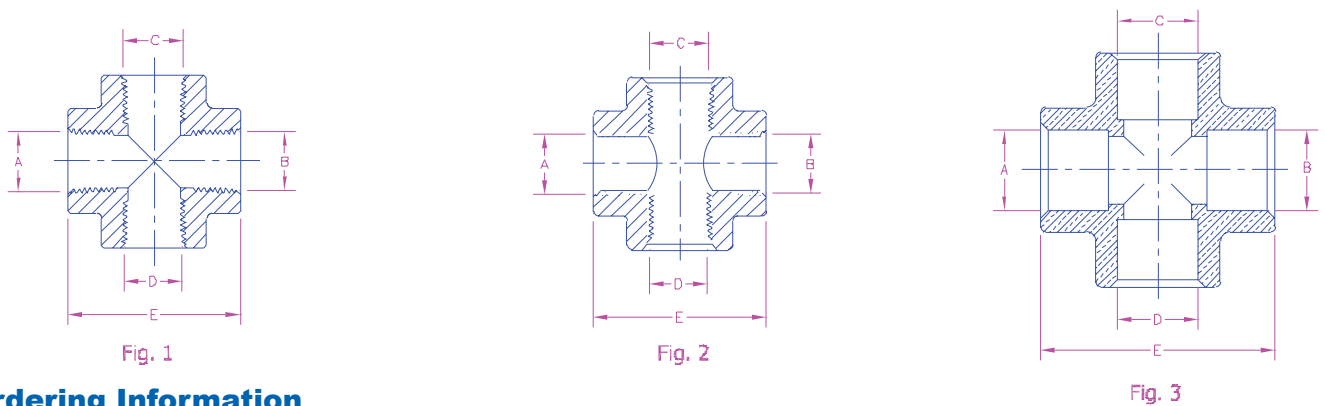

Ordering Information

Part Number	Figure	A (Female)	B (Female)	C (Female)	D (Female)	E (Ref.)	Working Pressure PSIG*				
1225-1	1	½" NPT	½" NPT	½" NPT	½" NPT	2¼"	3750				
HP1225-1						3"	4500				
1045						¾" NPT	¾" NPT	¾" NPT	¾" NPT	3"	4500
1225-3	2	.843-.847	.843-.847	½" NPT	½" NPT	2¼"	3750				
HP1225-3						3"	4500				
2222-2	3	1.053-1.057	1.053-1.057	¾" NPT	¾" NPT	3"	4500				
HP1225-4						.843-.847	.843-.847	.843-.847	.843-.847	3"	6000
2222-4						1.053-1.057	1.053-1.057	1.053-1.057	1.053-1.057	3"	4500

*Safety factor = 4:1

Repair Kits

Ordering Information - Valves

Kit Number	Part Number	Kit Contents
2505AC-80	2505AC	Seat disc, diaphragm, washers, gaskets.
2507AC-80	2507AC	
2511AC-80	2511AC	
2513AC-80	2513AC	
2553AC-80	2553AC 2553AAC	Diaphragm and seat disc assembly stem washer.
2554AC-80	2554AC 2554AAC	
CW6600G-80	CW6600G580 CW6600G581	Gasket, spring, spring retainer, washer.
7160-80B	7160V 7161V	Complete valve trim assembly.
9500-80K	UL9500 series NUL9500 Series**	Seat disc and retainer assembly, seal washer, packing ring set, washer.
9550-80	9550 Series	Seat disc, retainer assembly, seal washer, packing nut set, washer.
9550-3-80	9550 Series	Sleeve.
9550-4-80	9550 Series	Stem, back-up ring, o-ring, washer.
9560-80	9560 Series	CTFE Seat Disc & Retainer Assembly, Seal
9560C-80	9560C Series	CTFE Seat Disc & Retainer Assembly, Seal Monel Body Seat Insert
BK8400-80J	BK8404 Series BK8406 Series BK8408 Series BKY8408 Series BK9404 Series BK9406 Series BK9408 Series	Jam ring, o-ring, pressure seal rings (3), spring, tape, washer.
BK8400-80AJ	BK8404 Series BK8406 Series BK9404 Series BK9406 Series	Seat disc assembly, teflon o-ring.
BK8400-80BJ	BK8408 Series BK9408 Series	Seat disc assembly, teflon o-ring.
BKA8412-80J	BKA8412S	Jam ring, o-ring, pressure seal rings (3), spring, tape, washer.
BKA8412-80JA		O-ring seal, seat disc retainer assembly.
BK9400-80J	BK9410 Series	Jam ring, o-ring, pressure seal rings (3), spring, tape, washer.
BK9400-80AJ	BK9412 Series	Seat disc assembly, teflon o-ring.
BKY8408-80AJ	BKY8408 Series	Seat disc assembly and gasket.

Ordering Information - Retrofit Kits

Kit Number	Part Number	Kit Contents
ES8450R	T9450 Series T9460 Series	Stem assembly (4"), packing, bonnet, handwheel
BK9450R	9460 Series 9450 Series	Extended Bonnet Assembly Kit, Spring load packing for conversion of extended stem valves and topworks replacement
BKA8400R	BKA8412SE	Stem assembly, handwheel, seat assembly Converts SE Series to New Style S Series
T9464-80	T9450 Series 9450 Series T9460 Series 9460 Series	Complete valve trim assembly including handwheel
BK-9450-KIT	ES8450 Series ES9450 Series BK9450 Series	Extended Bonnet Assembly Kit, Spring load packing for conversion of extended stem valves and topworks replacement

Repair Kits

Ordering Information - Regulators

Kit Number	Part Number	Kit Contents (Qty)
BR-1684M-80N	BR-1684M Series	Diaphragm assembly, stem and seat assembly, seal.
BR-1686M-80N	BR-1686M Series	
1682Y-80	1682Y Series	Diaphragm assembly, stem and seat assembly seal.
1682M-80	1682M Series	Molded diaphragm assembly, stem and seat assembly seal.
1684Y-80	1684Y Series	Diaphragm assembly, stem and seat assembly seal, guide.
1684M-80	1684M Series	Molded diaphragm assembly, stem and seat assembly seal, guide.
1686Y-80	1686Y, 1688Y Series	Diaphragm assembly, stem and seat assembly seal.
1686M-80	1686M, 1688M Series	Molded diaphragm assembly, stem and seat assembly seal.
1686MHP-80	1686MHP, 1688MHP	Diaphragm assembly, stem and seat assembly, seal
1684MHP-80	1684MHP	
1684M-80	BR-1684M Series	Diaphragm assembly, stem and seat assembly, seal
1686M-80	BR-1686M Series	
BR-1784-80	BR-1784 Series, 1784 Series	Diaphragm assembly, stem and seat assembly, seal, Viton seat
BR-1784-80E	BR-1784 E Series, 1784 E Series	Diaphragm assembly, stem and seat assembly, seal, EPDM seat for CO2 Service
BR-1784ST	BR-1784 Series	T-Handle adjusting screw kit
BR-1784-7SKA BR-1784-7SKB BR-1784-7SKC	BR-1784 Series	Spring kit for BR-1784, "A" spring range, 5 to 55 psig delivery pressure BR-1784 "B" spring range, 40 to 110 psig delivery pressure Spring kit for BR-1784, "C" spring range, 100 to 200 psig delivery pressure
BR-1786-80	BR-1786 Series, BR-1788 Series, 1786 Series, 1788 Series	Diaphragm assembly, stem and seat assembly, seal, viton seat for oxygen service
BR-1786-80E	BR-1786 E Series, BR-1788 E Series, 1786 E Series, 1788 E Series	Diaphragm assembly, stem and seat assembly, seal, EPDM seat for CO2 service
BR-1786ST	BR-1786 Series, BR-1788 Series	T-handle adjusting screw kit
BR-1786-7SKA BR-1786-7SKB BR-1786-7SKC	BR-1786 Series	Spring kit for BR-1786, "A" spring range, 5 to 55 psig delivery pressure Spring kit for BR-1786, "B" spring range, 40 to 110 psig delivery pressure Spring kit for BR-1786, "C" spring range, 100 to 200 psig delivery pressure
BR-1788-7SKA BR-1788-7SKB BR-1788-7SKC	BR-1788 Series	Spring kit for BR-1788, "A" spring range, 5 to 55 psig delivery pressure Spring kit for BR-1788, "B" spring range, 40 to 110 psig delivery pressure Spring kit for BR-1788, "C" spring range, 100 to 200 psig delivery pressure
BR-1780SC	BR-1780 Series	Brass Bonnet Cap
2523HP-80A	M2523HP350, M2523HP540, M2523HP580, M2523HP590, M2523HP1320	Seat and centerpiece assembly, diaphragm assembly, nozzle, spring, washer, gaskets.
2523HP-80B	M2523HP320	
ECL-80	ECL22, ECL70, ECL100, ECL140	Diaphragm assembly, diaphragm gasket, poppet, retaining ring, spring, washer.
ECL-80A	ECL325	
RG-80	RG75, RG125	Backcap gasket, diaphragm assembly, diaphragm gasket, seat assembly.
RG-80A	RG300	
B-9472-80	B-9472	Diaphragm assembly, gasket, stem, and seat assembly.
B-9473-80	B-9473, B-9474	
B-9473M-80	B-9473M, B-9474M, BR-9473	Diaphragm assembly, gasket, stem, and seat assembly.

Stainless Steel Gate Valve for Cryogenic Service Goddard 110 Series

Features

- **Top Entry:** This valve can be permanently installed in the line and serviced from the top
 - **Soft Seated:** PCTFE Seat provides a bubble tight seal and is replaceable
 - **Construction:** Stainless steel body and bonnet
 - **Sizes:** ½" - 6" (15mm - 150mm)
 - **Ends:** RF Flange, Butt weld, Socket weld, Threaded (FNPT)
 - **Service:** Liquified and vaporized atmospheric gases, LNG
 - **Temperature Rating:** -325°F - 150°F (-196°C +65°C)
 - 100% Factory Tested
 - Clean for use in oxygen per CGA G-4.1
 - **Pressure Rating:** (Cold, Non-shock)
Class 150 valve - 275 PSIG (19 bar)
Class 300 valve - 720 PSIG (50 bar)
- ½" - 6" Class 150
PED Approved, Approved for US and Canada
½" - 6" Class 300
PED Approved, Approved for US and Canada



Goddard 110 Series

Ordering Information

Stainless Body • RF Flange Ends

150# Part Number	300# Part Number	Valve Size		Ends	Weight 150#		Weight 300#		Estimated CV
		Inches	MM		Lbs.	Kg	Lbs.	Kg.	
GS-00110W-8F	-	1"	25 mm	Flange	15	6.80	-	-	30.00
GS-00110W-12F	GS-00110W-12F3	1½"	40 mm		35	15.88	45	20.41	85.00
GS-00110W-16F	GS-00110W-16F3	2"	50 mm		35	15.88	50	22.68	100.00
GS-00110W-24F	GS-00110W-24F3	3"	80 mm		65	29.48	85	35.56	310.00
GS-00110W-32F	GS-00110W-32F3	4"	100 mm		90	40.82	120	54.43	700.00
GS-00110W-48F	GS-00110W-48F3	6"	150 mm		150	68.04	200	90.72	850.00

150# ANSI Class (275 PSIG Cold Working Pressure) 300# ANSI Class (720 PSIG Cold Working Pressure)

Stainless Body • Butt Weld, Socket Weld, Threaded Ends

150# Part Number	300# Part Number	Valve Size		Ends	Weight		Estimated CV
		Inches	MM		Lbs.	Kg.	
GS-00110W-4WA	-	½"	15 mm	Butt Weld SCH10	10	4.54	7.00
GS-00110W-4S3	GS-00110W-4S3	½"	15 mm	Socket Weld	15	6.80	7.00
GS-00110W-4T	-	½"	15 mm	Threaded	10	4.54	7.00
GS-00110W-6WA	-	¾"	20 mm	Butt Weld SCH10	10	4.54	23.00
GS-00110W-6S3	GS-00110W-6S3	¾"	20 mm	Socket Weld	15	6.80	23.00
GS-00110W-8WA	-	1"	25 mm	Butt Weld SCH10	10	4.54	30.00
GS-00110W-8S3	GS-00110W-8S3	1"	25 mm	Socket Weld	15	6.80	30.00
GS-110W-8T	-	1"	25mm	Threaded	10	4.54	30.00
GS-00110W-12WA	-	1½"	40 mm	Butt Weld SCH10	30	13.61	85.00
GS-00110W-12S3	GS-00110W-12S3	1½"	40 mm	Socket Weld	35	15.88	85.00
GS-00110W-16W3A	GS-00110W-16W3A	2"	50 mm	Butt Weld SCH10	35	15.88	100.00
GS-00110W-16W3J	GS-00110W-16W3J	2"	50 mm	Butt Weld SCH40	35	15.88	100.00
GS-00110W-16S	-	2"	50 mm	Socket Weld	30	13.61	100.00
GS-00110W-24W3A	GS-00110W-24W3A	3"	80 mm	Butt Weld SCH10	65	29.48	310.00
GS-00110W-24W3J	GS-00110W-24W3J	3"	80 mm	Butt Weld SCH40	65	29.48	310.00
GS-00110W-32W3A	GS-00110W-32W3A	4"	100 mm	Butt Weld SCH10	80	40.82	700.00
GS-00110W-32W3J	GS-00110W-32W3J	4"	100 mm	Butt Weld SCH40	80	40.82	700.00
GS-00110W-48WA	GS-00110W-48W3A	6"	150 mm	Butt Weld SCH10	120/150*	54.43/68.04*	850.00
GS-00110W-48WJ	GS-00110W-48W3J	6"	150 mm	Butt Weld SCH40	120/150*	54.43/68.04*	850.00

150# ANSI Class (275 PSIG Cold Working Pressure) 300# ANSI Class (720 PSIG Cold Working Pressure)

* Second number indicates valve for 300# part number.

Service: 300#-720 PSI Non-shock Cold • Service: 150#-275 PSI Non-shock Cold • Temperature Rating +150°F - 325°F

Stainless Steel Gate Valve for Cryogenic Service Goddard 110 Series

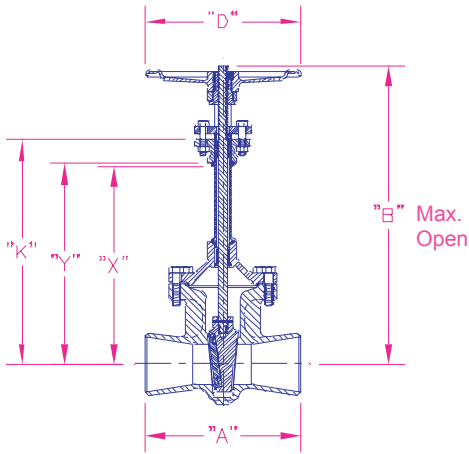

Socket Weld Ends

Size	"A" 150#	"A" 300#	"B"	"D"	"E"	"F"	"K"	"X"	"Y"
1/2"	3 3/4"	3 3/4"	17 3/4"	4 1/2"	.855	3/8"	12 3/4"	11 1/16"	11 3/8"
3/4"	3 3/4"	3 3/4"	17 3/4"	4 1/2"	1.065	1/2"	12 3/4"	11 1/16"	11 3/8"
1"	3 1/2"	4"	17 3/4"	4 1/2"	1.330	1/2"	12 3/4"	11 1/16"	11 3/8"
1 1/2"	4 5/8"	5"	21 7/8"	7"	1.915	1/2"	14"	12 5/16"	12 5/8"
2"	8 1/2"	N/A	21 7/8"	7"	2.406	5/8"	14"	12 5/16"	12 5/8"

• Special B,K,X & Y Dimensions Available

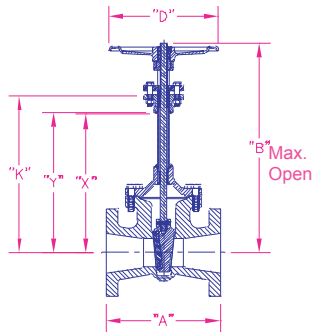

Raised Face Flange Ends*

Size	"A" 150#	"A" 300#	"B"	"D"	"K"	"X"	"Y"
1"	4 1/8"	N/A	17 3/4"	4 1/2"	12 3/4"	11 1/16"	11 3/8"
1 1/2"	4 5/8"	6 1/8"	21 1/8"	7"	14"	12 5/16"	12 5/8"
2"	7"	7 1/4"	21 1/8"	7"	14"	12 5/16"	12 5/8"
3"	8"	8 3/4"	31 1/2"	12"	20"	17 3/4"	18 1/16"
4"	9"	12"	33 3/4"	12"	21 1/2"	19 1/4"	19 9/16"
6"	10 1/2"	15 5/8"	41 1/2"	16"	26"	23 9/16"	23 7/8"

*Face-to-face dimensions (A) are Goddard standard not to ANSI standard.

• Special B,K,X & Y Dimensions Available

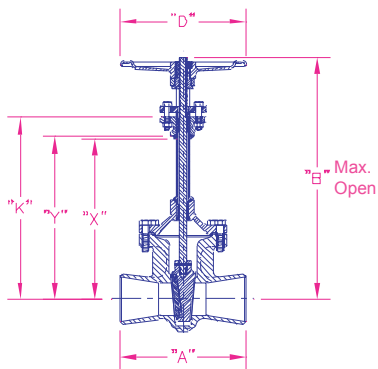

Butt Weld Ends

Size	"A" 150#	"A" 300#	"B"	"D"	"K"	"X"	"Y"
1/2"	4 1/4"	N/A	17 3/4"	4 1/2"	12 3/4"	11 1/16"	11 3/8"
3/4"	4 5/8"	N/A	17 3/4"	4 1/2"	12 3/4"	11 1/16"	11 3/8"
1"	5"	N/A	17 3/4"	4 1/2"	12 3/4"	11 1/16"	11 3/8"
1 1/2"	6"	6"	21 1/8"	7"	14"	12 5/16"	12 5/8"
2"	8 1/2"	8 1/2"	21 1/8"	7"	14"	12 5/16"	12 5/8"
3"	11 1/8"	11 1/8"	31 1/2"	12"	20"	17 3/4"	18 1/16"
4"	12"	12"	33 3/4"	12"	21 1/2"	19 1/4"	19 9/16"
6"	15 1/8"	15 5/8"	41 1/2"	16"	26"	23 9/16"	23 7/8"

• Special B,K,X & Y Dimensions Available

• Unless otherwise specified, Schedule 10 weld ends are supplied

Stainless Steel Globe Valve for Cryogenic Service Goddard 210 Series

Features

- **Top Entry:** This valve can be permanently installed in the line and serviced from the top
- **Soft Seated:** PCTFE Seat provides a bubble tight seal and is replaceable
- **Construction:** Stainless steel body and bonnet
- **Sizes:** ½" - 4" (15mm - 150mm)
- **Ends:** RF Flange, Butt weld, Socket weld, Threaded (FNPT)
- **Service:** Liquified and vaporized atmospheric gases, LNG
- **Temperature Rating:** -325°F - 150°F (-196°C +65°C)
- **Pressure Rating:** (Cold, Non-shock)
Class 150 valve - 275 PSIG (19 bar)
Class 300 valve - 720 PSIG (50 bar)

½" - 4" Class 150

PED Approved, Approved for US and Canada

½" - 4" Class 300

PED Approved, Approved for US and Canada

Our investment cast stainless steel is specified by leading industrial gas companies for storage tank and yard operations. Special bonnet extensions can be supplied for cold box applications. Valves for hydrogen use can be supplied



Goddard 210 Series

Ordering Information

Stainless Body • RF Flange Ends

150# Part Number	300# Part Number	Valve Size		Ends	150# Weight		300# Weight		Estimated CV
		Inches	MM		Lbs.	Kg.	Lbs.	Kg.	
GS-00210W-8F	GS-00210W-8F3	1"	25 mm	Flange	15	6.80	20	9.07	11.50
GS-00210W-16F	GS-00210W-16F3	2"	50 mm		35	15.88	40	18.14	40.00
GS-00210W-24F	GS-00210W-24F3	3"	80 mm		65	29.48	70	31.75	60.00
GS-00210W-32F	GS-00210W-32F3	4"	100 mm		90	40.82	95	43.09	175.00

150# ANSI Class (275 PSIG Cold Working Pressure)

300# ANSI Class (720 PSIG Cold Working Pressure)

Stainless Body • Butt Weld, Socket Weld, Threaded Ends

150# Part Number	300# Part Number	Valve Size		Ends	Weight		Estimated CV
		Inches	MM		Lbs.	Kg	
GS-00210W-4S3	GS-00210W-4S3	½"	15 mm	Socket Weld	15	6.80	3.90
GS-00210W-4T3	GS-00210W-4T3	½"	15 mm	Threaded	15	6.80	3.90
GS-00210W-6S3	GS-00210W-6S3	¾"	20 mm	Socket Weld	15	6.80	7.10
GS-00210W-6T3	GS-00210W-6T3	¾"	20 mm	Threaded	15	6.80	7.10
GS-00210W-8S3	GS-00210W-8S3	1"	25 mm	Socket Weld	15	6.80	11.50
GS-00210W-8T3	GS-00210W-8T3	1"	25 mm	Threaded	15	6.80	11.50
GS-00210W-12S3	GS-00210W-12S3	1½"	40 mm	Socket Weld	25	11.34	29.00
GS-00210W-16W3A	GS-00210W-16W3A	2"	50 mm	Butt Weld SCH10	35	15.88	40.00
GS-00210W-16W3J	GS-00210W-16W3J	2"	50 mm	Butt Weld SCH40	35	15.88	40.00
GS-00210W-24W3A	GS-00210W-24W3A	3"	80 mm	Butt Weld SCH10	55	24.95	60.00
GS-00210W-24W3J	GS-00210W-24W3J	3"	80 mm	Butt Weld SCH40	55	24.95	60.00
GS-00210W-32W3A	GS-00210W-32W3A	4"	100 mm	Butt Weld SCH10	80	36.29	175.00
GS-00210W-32W3J	GS-00210W-32W3J	4"	100 mm	Butt Weld SCH40	80	36.29	175.00

150# ANSI Class (275 PSIG Cold Working Pressure)

300# ANSI Class (720 PSIG Cold Working Pressure)

* Second number indicates valve for 300# part number.

Service: 300#-720 PSI Non-shock Cold • Service: 150#-275 PSI Non-shock Cold • Temperature Rating +150°F to -325°F

Stainless Steel Globe Valve for Cryogenic Service Goddard 210 Series

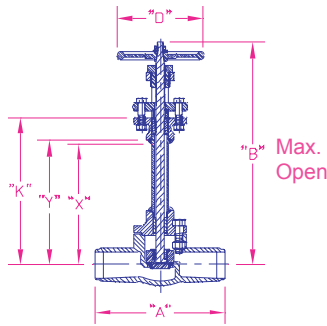

Butt Weld Ends

Size	"A"	"B"	"D"	"K"	"X"	"Y"
2"	10½"	22¼"	7"	15"	12¾"	13 ¹ / ₁₆ "
3"	Δ12"	30½"	10"	21½"	19 ¹ / ₁₆ "	19 ³ / ₈ "
4"	Θ13½"	36¾"	12"	24¼"	21 ¹¹ / ₁₆ "	22"
6"	17½"	43¾"	18"	33 ³ / ₁₆ "	28 ¹³ / ₁₆ "	29 ³ / ₁₆ "

Δ For SCH. 40 A=12½"

Θ For SCH. 40 A=14"

* Unless otherwise specified, SOH 10 weld ends are supplied

• Special B,K,X & Y dimensions available.

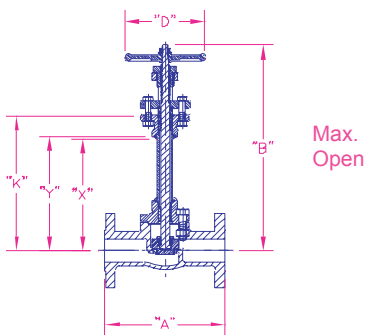

Raised Face Flange Ends*

Size	"A" 150#	"A" 300#	"B"	"D"	"K"	"X"	"Y"
1"	6½"	8"	18 ¹ / ₈ "	5"	12¾"	11 ¹ / ₁₆ "	11 ³ / ₈ "
2"	8"	10½"	22¼"	7"	15"	12¾"	13 ¹ / ₁₆ "
3"	9½"	12½"	30½"	10"	21½"	19 ¹ / ₁₆ "	19 ³ / ₈ "
4"	11½"	14"	36¾"	12"	24¼"	21 ¹¹ / ₁₆ "	22"

• Special B,K,X & Y dimensions available.

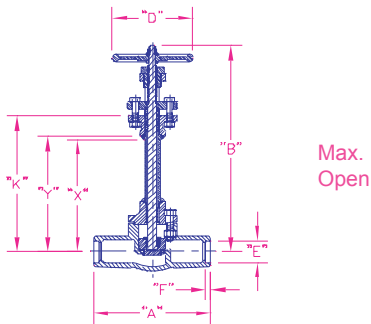

Socket Weld Ends

Size	"A"	"B"	"D"	"E"	"F"	"K"	"X"	"Y"
½"	5"	18 ¹ / ₈ "	5"	.855	¾"	12¾"	11 ¹ / ₁₆ "	11 ³ / ₈ "
¾"	5"	18 ¹ / ₈ "	5"	1.065	½"	12¾"	11 ¹ / ₁₆ "	11 ³ / ₈ "
1"	5"	18 ¹ / ₈ "	5"	1.330	½"	12¾"	11 ¹ / ₁₆ "	11 ³ / ₈ "
1½"	10¼"	22¼"	7"	1.915	½"	15"	12¾"	13 ¹ / ₁₆ "

• Special B,K,X & Y dimensions available.

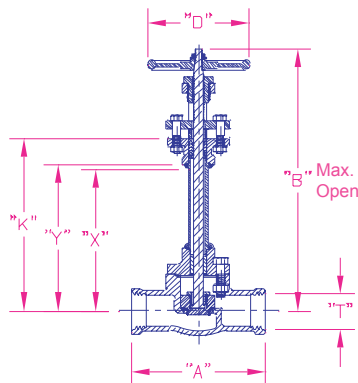

Threaded Ends

Size	"T" - NPT	"A"	"B"	"D"	"K"	"X"	"Y"
½"	½"-14	5"	18 ¹ / ₈ "	5"	12¾"	11 ¹ / ₁₆ "	11 ³ / ₈ "
¾"	¾"-14	5"	18 ¹ / ₈ "	5"	12¾"	11 ¹ / ₁₆ "	11 ³ / ₈ "
1"	1"-11½"	5¾"	18 ¹ / ₈ "	5"	12¾"	11 ¹ / ₁₆ "	11 ³ / ₈ "

• Special B,K,X & Y dimensions available.

Stainless Steel Globe Valve for Cryogenic Service Goddard 231 Series

Features

- **Top Entry:** Rugged stainless steel * soft seated cryogenic globe valve. This valve can be permanently installed in the line and serviced from the top
- **Soft Seated:** PCTFE Seat provides a bubble tight seal and is replaceable
- **Construction:** One piece investment cast bonnet eliminates welded joint in topworks
- **Stem Packing:** Proprietary Goddard system utilizing GRAFOIL® flexible graphite
- **Sizes:** ¼" through 1½" (6mm through 40mm)
- **Ends:** Socket weld, Butt weld
- **Service:** Liquified and Gaseous hydrogen service only (see series 232 for non-hydrogen service)
- **Temperature Rating:** -425°F to 150°F (-254°C to +65°C)
- **Pressure Rating:** (Cold, Non-shock)
300 PSIG (20 Bar)
400 PSIG (27 Bar)

*Stainless steel ASTM A351-CF3M (316L)

PED Approved, Approved for US and Canada
Designed to ASME B16.34

A rugged construction and easy access are design features which provide minimum installation and maintenance cost while maintaining superior performance and operator safety. This valve replaces higher cost bellows-seated valves in many applications. The proprietary Goddard GRAFOIL® stem packing system provides excellent performance when the valve operates in liquid hydrogen service.



Goddard 231 Series

Ordering Information

Stainless Body • 400 PSIG Socket Weld Ends

Part Number	Valve size Inches	Valve Size mm	Ends	Weight Lbs.	Weight Kgs.	Estimated Cv
S-000231-2S4	¼"	6 mm	Socket Weld	6 lbs.	2.72 Kgs.	1.30
S-000231-4S4	½"	15 mm	Socket Weld	6 lbs.	2.72 Kgs.	3.90
S-000231-6S4	¾"	20 mm	Socket Weld	10 lbs.	4.54 Kgs.	7.10
S-000231-8S4	1"	25 mm	Socket Weld	10 lbs.	4.54 Kgs.	10.50
S-000231-12S4	1½"	40 mm	Socket Weld	15 lbs.	6.80 Kgs.	25.00

Stainless Body • 300 PSIG Butt Weld Ends

Part Number	Valve size Inches	Valve Size mm	Ends	Weight Lbs.	Weight Kgs.	Estimated Cv
S-000231-4WA	½"	15 mm	Butt Weld	6 lbs.	2.72 Kgs.	3.90
S-000231-8WA	1"	25 mm	Butt Weld	10 lbs.	4.54 Kgs.	10.50
S-000231-12WA	1½"	40 mm	Butt Weld	15 lbs.	6.80 Kgs.	25.00

Stainless Steel Globe Valve for Cryogenic Service Goddard 231 Series

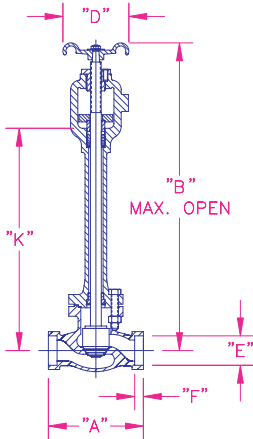

Pressure Rating 400 PSIG
 Temperature Rating +150° F to - 425° F
 This valve is not approved for gaseous and/or liquid oxygen service
 For oxygen service use Goddard series 232H cryogenic globe valve

Dimensional data
 All Dimensional Data are in inches.

SOCKET WELD ENDS

Size	"A"	"B"	"D"	"E"	"F"	"K"
1/4"	4 1/4"	14 ⁹ / ₁₆ "	2 3/8"	0.560	0.375	10 ³ / ₁₆ "
1/2"	4 1/4"	14 ⁹ / ₁₆ "	2 3/8"	0.860	0.375	10 ³ / ₁₆ "
3/4"	5 3/8"	17"	3"	1.070	0.500	11 1/2"
1"	5 3/8"	17"	3"	1.335	0.500	11 1/2"
1 1/2"	6 1/2"	18 ¹⁴ / ₁₆ "	4"	1.920	0.500	12 ¹⁵ / ₁₆ "

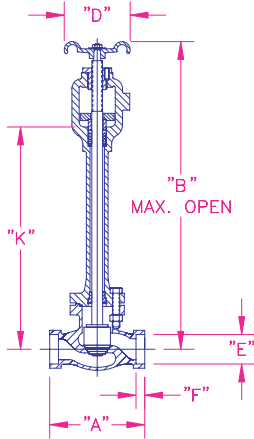

Pressure Rating 300 PSIG
 Temperature Rating +150° F to - 425° F
 This valve is not approved for gaseous and/or liquid oxygen service
 For oxygen service use Goddard series 232H cryogenic globe valve

Dimensional data
 All Dimensional Data are in inches.

BUTT WELD ENDS

Size	"A"	"B"	"D"	"K"
1/2"	4 1/4"	14 9/16"	2 3/8"	10 3/16"
1"	5"	17"	3"	11 1/2"
1 1/2"	6 1/2"	18 7/8"	4"	12 5/16"

Stainless Steel Globe Valve for Cryogenic Service Goddard 232 Series

Features

- **Top Entry:** Rugged stainless steel * soft seated cryogenic globe valve. This valve can be permanently installed in the line and serviced from the top
- **Soft Seated:** PCTFE Seat provides a bubble tight seal and is replaceable
- **Construction:** One piece investment cast bonnet eliminates welded joint in topworks.
- **Sizes:** ½" through 1½" (15mm through 40mm)
- **Ends:** Socket weld and Butt weld
- **Service:** Liquified and vaporized atmospheric gases, LNG
- **Temperature Rating:** -325°F to 150°F (-198°C to +65°C)
- **Pressure Rating:** (Cold, Non-shock)
300 PSIG (20 Bar)
400 PSIG (27 Bar)

*Stainless steel ASTM A351-CF3M (316L)

PED Approved, Approved for US and Canada
Designed to ASME B16.34

A rugged construction and easy access are design features which provide minimum installation and maintenance cost while maintaining superior performance and operator safety.



Goddard 232 Series

Ordering Information

Stainless Body Socket Weld Ends 400 PSIG

Part Number	Valve size Inches	Valve Size mm	Ends	Weight Lbs.	Weight Kgs.	Estimated Cv
S-000232-4S4	½"	15 mm	Socket Weld	6 lbs.	2.72 Kgs.	3.90
S-000232-8S4	1"	25 mm	Socket Weld	10 lbs.	4.54 Kgs.	10.50

High Purity Cryogenic Bonnet Nickel Plated Naval Brass Yoke Bushing Stainless Steel Body Butt Weld Ends 300 PSIG

Part Number	Valve size Inches	Valve Size mm	Ends	Weight Lbs.	Weight Kgs.	Estimated Cv
S-232HCB-4WA	½"	15 mm	Butt Weld	6 Lbs.	2.72 Kgs.	3.90
S-232HCB-8WA	1"	25 mm	Butt Weld	10 Lbs.	4.54 Kgs.	10.50
S-232HCB-12WA	1½"	40 mm	Butt Weld	15 Lbs.	6.80 Kgs.	25.00

High Purity Cryogenic Bonnet Nickel Plated Naval Brass Yoke Bushing, Stainless Steel Body Socket Weld Ends 400 PSIG

Part Number	Valve size Inches	Valve Size mm	Ends	Weight Lbs.	Weight Kgs.	Estimated Cv
S-232HCB-4S4	½"	15 mm	Socket Weld	6 lbs.	2.72 Kgs.	3.90
S-232HCB-8S4	1"	25 mm	Socket Weld	10 Lbs.	4.54 Kgs.	10.50
S-232HCB-12S4	1½"	40 mm	Socket Weld	15 Lbs.	6.80 Kgs.	25.00

Stainless Steel Globe Valve for Cryogenic Service Goddard 232 Series

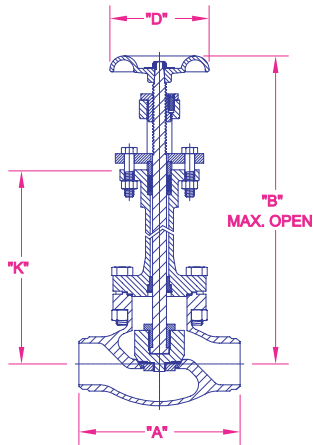

Pressure rating 300 PSIG non-shock cold
 Temperature rating +150° F to -325° F
 Dimensional Data
 All dimensions are in inches

BUTT WELD ENDS

Size	"A"	"B"	"D"	"K"
½"	4¼"	14 ⁹ / ₁₆ "	2 ³ / ₈ "	10 ³ / ₁₆ "
1"	5"	17"	3"	11 ½"
1½"	6"	18 ⁵ / ₈ "	4"	12 ⁵ / ₁₆ "

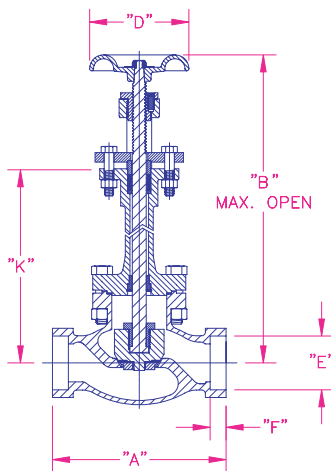

Pressure rating 400 PSIG non-shock cold
 Temperature rating +150° F to -325° F
 Dimensional Data
 All dimensions are in inches

SOCKET WELD ENDS

Size	"A"	"B"	"D"	"E"	"F"	"K"
½"	4¼"	14 ⁹ / ₁₆ "	2 ³ / ₈ "	0.860	0.375	10 ³ / ₁₆ "
1"	5 ³ / ₈ "	17"	3"	1.335	0.500	11 ½"
1½"	6½"	18 ⁵ / ₈ "	4"	1.920	0.500	12 ⁵ / ₁₆ "

RegO - Goddard Stainless Steel Globe Valve for Cryogenic Service SK Series

Application

The SK Series globe valves are designed for the handling of cryogenic liquids through trailer, bulk tanks and piping configurations. Our time tested spring loaded stem packing and superior seat design provide for long life and easy maintenance

Features

- **Superior Flow:** Provides high Cv for rapid and reliable trailer and tank loading and unloading.
- **Top Entry:** Rugged stainless steel soft seated cryogenic globe valve. This valve can be permanently installed in the line and serviced from the top.
- **Soft Seated:** PCTFE seat provides a virtually bubble tight seal and is replaceable.
- **Stem Packing:** RegO BK Series V-Ring spring loaded packing provides extended service life without constant packing adjustment.
- **Sizes:** 1/4" Through 2" - 8. mm through 50mm
- **Ends:** Socket weld and butt weld.
- **Service:** Liquefied and vaporized atmospheric gases, LNG
- **Temperature Rating:** -325°F to +150°F (-198°C to +65°C)
- **Pressure Rating:** (Cold, Non-Shock) 725 PSIG (50 BAR) Class 300



Materials

Body	Stainless Steel
Bonnet and Tube	Stainless Steel
Seat Disk	PCTFE
Seat Retainer.....	Brass
Packing Spring/Washer.....	Stainless Steel
Stem	Stainless Steel
Packing.....	PTFE
Handwheel.....	Chromate Coated Ductile Iron
Bonnet Gasket.....	PTFE
Fasteners (Bolts)	Stainless Steel

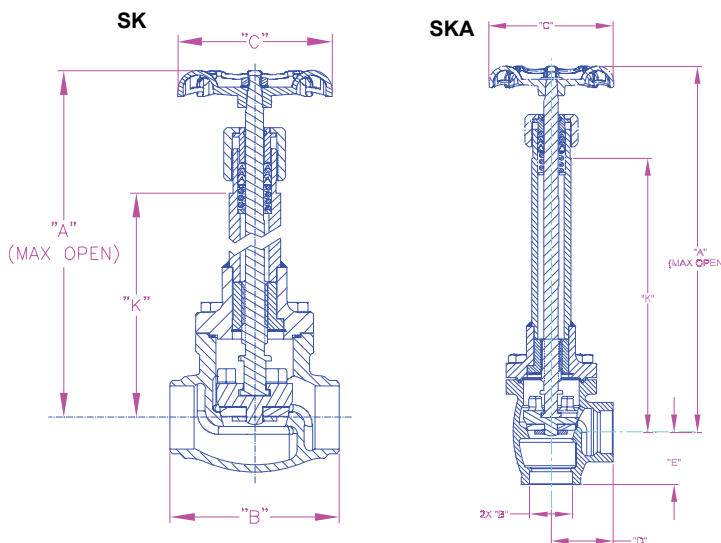

Ordering Information

Part Number	Size	Connection	"A"	"B"	"C"	"K"	Cv	
SK9402BW	1/4"	Buttweld	14.40	2.68	3.00	10.65	-	
SK9404BW	1/2"							
SK9406BW	3/4"			3.62	4.00	10.49		
SK9408BW	1"							
SK9412BW	1 1/2"			4.75	4.75	10.42		28.3
SK9416BW	2"			5.75	5.25	11.11		53
SKA9412SE	1 1/2"	Socket Weld	14.60		4.75	10.42	26.4	

Bronze Gate Valves for Cryogenic Service Goddard 302, 306, 310 & 310X Series

Features

- **Top Entry:** This union bonnet valve can be permanently installed in the line and serviced from the top
- **Construction:**
Bronze cast body and bonnet
Rugged construction for long life
Straight through design for high CV
Designed with unique KOLD-SEAL™
- **Sizes:** ½" - 3" (15mm - 80mm)
- **Ends:** Threaded (FNPT), Sil Braze Tube (SBT), or with stainless steel pipe nipples brazed in
- **Service:** Liquified and vaporized atmospheric gases, LNG
- **Temperature Rating:** -325°F - +150°F (-196°C +65°C)
- **Pressure Rating:** (Cold, Non-shock)
310, 310x Series 300 PSIG
302 Series 400 PSIG
306 Series 600 PSIG

Designed to MSS SP-80 and ASME B31.3
Sizes 1.5" - 3.0" PED approved per EN 10204, 3.1
- **Soft Seated** Series 310 & 310X: Solid wedge with PCTFE (Neoflon®) provides a bubble tight seal and is replaceable.
- **Metal Seated** Series 302 & 306: Split wedge made of Bronze and also replaceable.

Gate design for high flow applications.
Straight-through flow for highest CV rating in the industry.

302, 306 Non-Extended stem for selective cold gas applications

310, 310X Extended stem ideal for cryogenic supply applications



Bronze Gate Valves for Cryogenic Service

Goddard 302, 306, 310 & 310X Series

Ordering Information

302 Series

Bronze Gate Valves
Bronze Body Non-Extended Bonnet, Split Wedge
For selected cold gas operations
400 PSIG COLD WORKING PRESSURE

Part Number	NPT Size Inches	NPT Size mm	Ends	Weight Lbs.	Weight Kgs.	Estimated CV
B-000302-4T4	½"	15	Threaded	1.50	0.70	19.80
B-000302-20T4	2½"	65	Threaded	17.50	8.00	372.00
B-000302-24T4	3"	80	Threaded	26.00	11.80	588.00

Part Number	SBT Size Inches*	SBT Size mm*	Ends	Weight Lbs.	Weight Kgs.	Estimated CV
B-000302-4S4	½"	15	Silver Braze	1.25	0.60	19.80
B-000302-6S4	¾"	20	Silver Braze	2.25	1.00	36.00
B-000302-8S4	1"	25	Silver Braze	3.00	1.40	60.80
B-000302-12S4	1½"	40	Silver Braze	6.00	2.70	152.00
B-000302-16S4	2"	50	Silver Braze	9.50	4.30	245.00
B-000302-20S4	2½"	65	Silver Braze	14.50	6.60	372.00
B-000302-24S4	3"	80	Silver Braze	22.00	10.00	588.00

*Nominal Size

306 Series

600 PSIG Bronze Body, Non-Extended Bonnet, Split Wedge

Part Number	NPT Size Inches	NPT Size mm	Ends	Weight Lbs.	Weight Kgs.	Estimated CV
B-000306-6T6	¾"	20	Threaded	2.25	1.00	36.00
B-000306-8T6	1"	25	Threaded	3.00	1.40	60.80
B-000306-12T6	1½"	40	Threaded	6.00	2.70	152.00
B-000306-16T6	2"	50	Threaded	9.50	4.30	245.00

310 Series

300 PSIG Bronze Body, Extended Bonnet, Solid Wedge, Soft Seat

Part Number	NPT Size Inches	NPT Size mm	Ends	Weight Lbs.	Weight Kgs.	Estimated CV
B-000310-20T	2½"	65	Threaded	14.50	6.60	372.00
B-000310-24T	3"	80	Threaded	22.00	10.00	588.00

Part Number	SBT Size Inches *	SBT Size mm *	Ends	Weight Lbs.	Weight Kgs.	Estimated CV
B-000310-24S	3"	80	Silver Braze	22.00	10.00	588.00

*Nominal Size

310X Series

Short Top Works for Trailer Service

300 PSIG Bronze Body, Extended Bonnet, Solid Wedge, Soft Seat

Part Number	NPT Size Inches	NPT Size mm	Ends	Weight Lbs.	Weight Kgs.	Estimated CV
B-000310X-20T	2½"	65	Threaded	14.50	6.60	372.00
B-000310X-24T	3"	80	Threaded	22.00	10.00	588.00

Part Number	SBT Size Inches *	SBT Size mm *	Ends	Weight Lbs.	Weight Kgs.	Estimated CV
B-000310X-24S	3"	80	Silver Braze	22.00	10.00	588.00

*Nominal Size

Bronze Gate Valves for Cryogenic Service Goddard 302, 306 Series

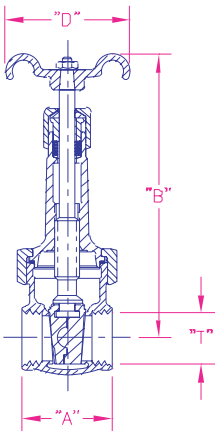

302 Series

MAWP: 400 PSIG Non-Shock Cold Temperature Rating +150° F to -325°F
Non-Extended Valve for selective cold gas applications

Dimensional Data

All dimensions are in inches

Threaded End (NPT)

Size	"A"	"B"	"D"	"T" NPT
1/2"	2.34"	5.81"	2.37"	1/2"
3/4"	2.50"	6.94"	2.75"	3/4"
1"	2.84"	8.43"	3.00"	1"
1 1/2"	3.43"	11.19"	4.00"	1 1/2"
2"	3.81"	13.19"	4.75"	2"
2 1/2"	4.68"	15.81"	5.25"	2 1/2"
3"	5.12"	18.25"	6.12"	3"

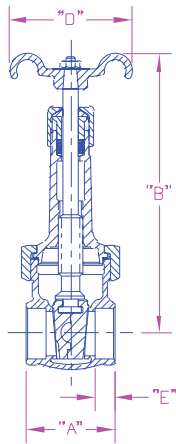

Sil Braze End

Size	"A"	"B"	"D"	"T" NPT
1/2"	2.50"	5.81"	2.37"	.38"
3/4"	3"	6.94"	2.75"	.40"
1"	3.25"	8.43"	3"	.43"
1 1/2"	4"	11.19"	4"	.62"
2"	4.5"	13.19"	4.75"	.65"
2 1/2"	5.25"	15.81"	5.25"	.78"
3"	6"	18.25"	6.12"	.82"

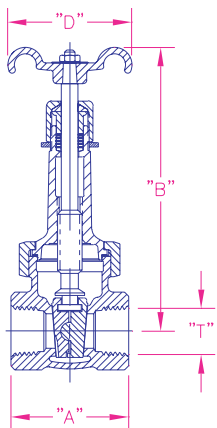

306 Series

MAWP: 600 PSIG Non-Shock Cold-Temperature Rating +150° F to -325°F
Non-Extended Valve for selective cold gas applications

Dimensional Data

All dimensions are in inches

Size	"A"	"B"	"D"	"T" NPT
3/4"	2.5"	6.93"	2 3/4"	3/4"
1"	2.84"	8.43"	3"	1"
1 1/2"	3.43"	11.18"	4"	1 1/2"
2"	3.81"	13.81"	4 3/4"	2"

Bronze Gate Valves for Cryogenic Service Goddard 310 & 310X Series

310 Series

MAWP: 300 PSIG Non-Shock Cold-Temperature Rating +150° F to -325°F
Extended Valve for selective cold gas applications

Dimensional Data

All dimensions are in inches

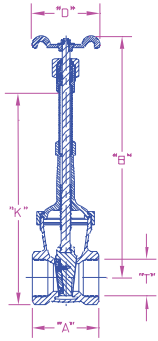

Threaded End (NPT)

Size	"A"	"B"	"D"	"K"
2½"	6"	25.38"	6.12"	16.30"
3"				

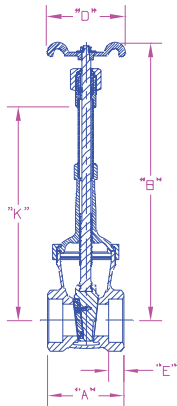

Sil Braze End

Size	"A"	"B"	"D"	"E"	"K"
2½"	6"	25.38"	6.12"	.03"	16.30"
3"					

310X Series

MAWP: 300 PSIG Non-Shock Cold-Temperature Rating +150° F to -325°F

Extended Valve for selective cold gas applications, Ideal for Trailer Service

Dimensional Data

All dimensions are in inches

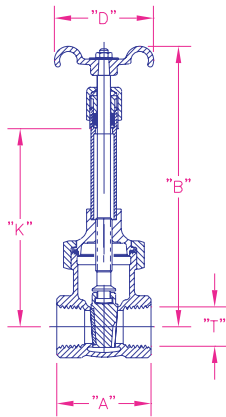

Threaded End (NPT)

Size	"A"	"B"	"D"	"K"
2½"	6"	20.38"	6.12"	11.5"
3"				

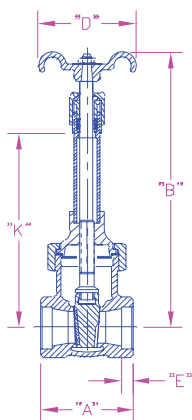

Sil Braze End

Size	"A"	"B"	"D"	"E"	"K"
2½"	6"	20.38"	6.12"	0.3"	11.5"
3"					

Extended Bonnet Bronze Gate Valve for Cryogenic Service Goddard 322 and 326 Series

Features

- **Top Entry:** This union bonnet valve can be permanently installed in the line and serviced from the top
- **Construction:**
 - Bronze cast body and Internals
 - Rugged construction for long life
 - Straight through construction for high CV
 - Designed with unique KOLD-SEAL™
 - Standard split wedge design provides better sealing and cycle life
- **Sizes:** ½" - 3" (15mm - 80mm)
- **Ends:** Threaded (FNPT), Sil Braze Tube (SBT), Silver Brazed Pipe (SBP) or with stainless steel pipe nipples brazed in
- **Service:** Liquified and vaporized atmospheric gases, LNG
- **Temperature Rating:** -325°F - 150°F (-196°C + 65°C)
- **Pressure Rating:** (Cold, Non-shock)
 - 322 Series 400 PSIG
 - 326 Series 600 PSIG

Designed to MSS SP-80 and ASME B31.3
Series 1.5" to 3" PED Approved per EN 10204, 3.1

**Ideal for cryogenic supply and storage handling applications.
Straight-through flow for highest CV rating in the industry.**

Also available with GRAFOIL® packing



Extended Bonnet Bronze Gate Valve for Cryogenic Service Goddard 322 and 326 Series

Ordering Information

322 Series

Bronze Gate Valves
400 PSIG COLD WORKING PRESSURE

Part Number	NPT Size Inches	NPT Size mm	Ends	Weight Lbs.	Weight Kgs.	Estimated CV
B-000322-20T4	2½"	65 mm	Threaded	19.00	8.64	372.00
B-000322-24T4	3"	80 mm	Threaded	28.00	121.73	588.00

Part Number	SBT Size Inches*	SBT Size mm	Ends	Weight Lbs.	Weight Kgs.	Estimated CV
B-000322-4S4	½"	15 mm	Silver Braze	1.75	0.80	19.80
B-000322-6S4	¾"	20 mm	Silver Braze	2.25	1.02	36.00
B-000322-8S4	1"	25 mm	Silver Braze	3.50	1.59	60.80
B-000322-12S4	1½"	40 mm	Silver Braze	7.50	3.41	152.00
B-000322-16S4	2"	50 mm	Silver Braze	11.25	5.11	245.00
B-000322-20S4	2½"	65 mm	Silver Braze	17.00	7.73	372.00
B-000322-24S4	3"	80 mm	Silver Braze	24.00	10.91	588.00

*Nominal Size

326 Series

Bronze Gate Valves
600 PSIG COLD WORKING PRESSURE

Part Number	NPT Size Inches	NPT Size mm	Ends	Weight Lbs.	Weight Kgs.	Estimated CV
B-000326-4T6	½"	15 mm	Threaded	1.75	0.80	19.80
B-000326-6T6	¾"	20 mm	Threaded	2.25	1.02	36.00
B-000326-8T6	1"	25 mm	Threaded	4.00	1.82	60.80
B-000326-12T6	1½"	40 mm	Threaded	8.25	3.75	152.00
B-000326-16T6	2"	50 mm	Threaded	12.50	5.68	245.00

Extended Bonnet Bronze Gate Valve for Cryogenic Service Goddard 322 and 326 Series

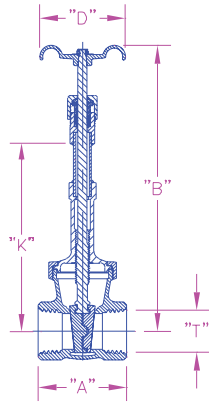

322 Series

MAWP: 400 PSIG Non-Shock Cold
Temperature Rating +150° F to -325°F
Dimensional Data

All dimensions are in inches

Threaded End (NPT)

Size	"A"	"B"	"D"	"K"
1/2"	2.34"	9.38"	2.37"	5.5"
3/4"	2.5"	10.56"	2.75"	6.12"
1"	2.84"	12.38"	3"	7.68"
1 1/2"	3.43"	17"	4"	10.87"
2"	3.81"	19.62"	4.75"	12.38"
2 1/2"	4.68"	22.5"	5.25"	14.5"
3"	5.12"	24.87"	6.12"	16.31"

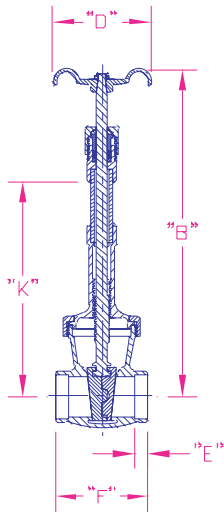

Sil Braze End

Size	"A"	"B"	"D"	"K"	"E"
1/2"	2.5"	9.38"	2.37"	5.5"	.38"
3/4"	3"	10.56"	2.75"	6.12"	.40"
1"	3.25"	12.38"	3"	7.68"	.43"
1 1/2"	4"	17"	4"	10.87"	.62"
2"	4.5"	19.62"	4.75"	12.38"	.65"
2 1/2"	5.25"	22.5"	5.25"	14.5"	.78"
3"	6"	24.87"	6.12"	16.31"	.82"

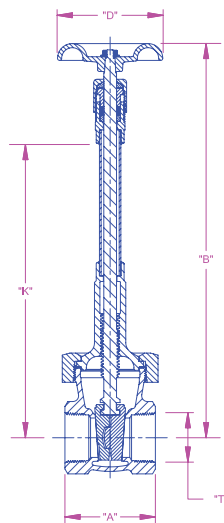

326 Series

MAWP: 600 PSIG Non-Shock Cold
Temperature Rating +150° F to -325°F
Dimensional Data

All dimensions are in inches

Threaded End (NPT)

Size	"A"	"B"	"D"	"K"
1/2"	2.34"	9.37"	2 1/4"	5.5"
3/4"	2.5"	10.56"	2 3/4"	6.12"
1"	2.34"	12.37"	3"	7.6"
1 1/2"	3.43"	17"	4"	10.87"
2"	3.81"	19.62"	4 3/4"	12.37"

Bronze Globe Valve for Cryogenic Service

Goddard 202X Series Including 206LL, 206GF, 206ULL, 206BLL

Features

- **Top Entry:** This union bonnet valve can be permanently installed in the line and serviced from the top
- **Construction:** Bronze cast body and bonnet
Rugged construction for long life
- **Designed with the unique Kold-Seal™** and high CV. Standard PTFE seat design assures bubble tight seating and high cycle life
- **Sizes:** ¼" through 2" (8mm through 50mm)
- **Ends:** Threaded (FNPT), Sil Braze Tube (SBT), or with stainless steel pipe nipples brazed in.
- **Service:** Liquified and vaporized atmospheric gases, LNG
- **Temperature Rating:** -325°F to 150°F (-196°C to +65°C)
- **Pressure Rating:** (Cold, Non-shock)
202 Series Rated for 400 PSIG
206 Series Rated for 600 PSIG
Sizes 1.5" to 2.0" PED approved per EN10204, 3.1
- **Kold-Seal™ Technology assures tight seal preventing cryogen gas loss. Non-extended stem for selective cold gas service.**



Ordering Information

202X

Bronze Globe Valves

Non-Extended Stem - Conical Seat

400 PSIG Cold Working Pressure

For selective Cold Gas Applications

Threaded End

Part Number	NPT Valve size Inches	Valve Size mm	Ends	Weight Lbs.	Weight Kgs.	Estimated Cv
B-00202X-12T4	1½"	40 mm	Threaded	6.50 Lbs.	3.00 Kgs.	29.00
B-00202X-16T4	2"	50 mm	Threaded	10.50 Lbs.	4.80 Kgs.	50.00

Sil Braze Ends

Part Number	SBT Valve size Inches *	Valve Size mm *	Ends	Weight Lbs.	Weight Kgs.	Estimated Cv
B-00202X-4S4	½"	15 mm	Silver Braze	1.50 Lbs.	0.7 Kgs.	3.90
B-00202X-8S4	1"	25 mm	Silver Braze	3.25 Lbs.	1.50 Kgs.	11.50
B-00202X-12S4	1½"	40 mm	Silver Braze	6.50 Lbs.	3.00 Kgs.	29.00
B-00202X-16S4	2"	50 mm	Silver Braze	10.50 Lbs.	4.80 Kgs.	50.00

* Nominal Size

Bronze Globe Valve for Cryogenic Service Goddard 202X Series Including 206LL, 206GF, 206ULL, 206BLL

206GF

Bronze Globe Valves

Non-Extended Stem - PFA seat with high temperature, low permeability GRAFOIL® packing and gasket.

600 PSIG Cold Working Pressure, For Selective Cold Gas Applications, High Temperature Service Rating +350°F

Threaded Ends

Part Number	NPT Valve size Inches	Valve Size mm	Ends	Weight Lbs.	Weight Kgs.	Estimated Cv
VB-0206GF-2T6	¼"	8 mm	Threaded	1.25 Lbs.	0.6 Kgs.	1.30
VB-0206GF-4T6	½"	15 mm	Threaded	1.50 Lbs.	0.70 Kgs.	3.90
VB-0206GF-6T6	¾"	20 mm	Threaded	2.50 Lbs.	1.10 Kgs.	7.10
VB-0206GF-8T6	1"	25 mm	Threaded	3.50 Lbs.	1.60 Kgs.	11.50
VB-0206GF-12T6	1½"	40 mm	Threaded	7.00 Lbs.	3.20 Kgs.	29.00
VB-0206GF-16T6	2"	50 mm	Threaded	11.75 Lbs.	5.30 Kgs.	50.00

206LL

Bronze Globe Valves, Non-Extended Stem, Live Loaded Packing, 600 PSIG Cold Working Pressure For Selective Cold Gas Applications

Threaded Ends

Part Number	NPT Valve size Inches	Valve Size mm	Ends	Weight Lbs.	Weight Kgs.	Estimated Cv
B-0206LL-2T6	¼"	8 mm	¼" NPT	1.25 Lbs.	0.6 Kgs.	1.30
B-0206LL-3T6	⅜"	10 mm	⅜" NPT	1.25 Lbs.	0.6 Kgs.	2.40
B-0206LL-4T6	½"	15 mm	½" NPT	1.75 Lbs.	0.8 Kgs.	3.90
B-0206LL-6T6	¾"	20 mm	¾" NPT	2.5 Lbs.	1.1 Kgs.	7.10
B-0206LL-8T6	1"	25 mm	1" NPT	3.5 Lbs.	1.6 Kgs.	11.50

Sil Brazed Ends

Part Number	SBT Valve size Inches *	Valve Size mm	Ends	Weight Lbs.	Weight Kgs.	Estimated Cv
B-0206LL-4S6	½"	10 mm	Silver Braze	1.25 Lbs.	0.6 Kgs.	3.90
B-0206LL-6S6	¾"	15 mm	Silver Braze	1.75 Lbs.	0.8 Kgs.	7.10
B-0206LL-8S6	1"	20 mm	Silver Braze	2.5 Lbs.	1.1 Kgs.	11.50

* Nominal Size

206ULL

Bronze Globe Valves, Non-Extended Stem, Live Loaded Packing - Union Bonnet, 600 PSIG Cold Working Pressure For Selective Cold Gas Applications

Sil Brazed Ends

Part Number	SBT Valve size Inches	Valve Size mm	Ends	Weight Lbs.	Weight Kgs.	Estimated Cv
B-206ULL-12S6	1½"	40 mm	Silver Braze	7 Lbs.	3.2 Kgs.	29.00
B-206ULL-16S6	2"	50 mm	Silver Braze	11.75 Lbs.	5.3 Kgs.	50.00

206BLL

Bronze Globe Valves, Non-Extended Stem, Live Loaded Packing - Bolted Bonnet, 600 PSIG Cold Working Pressure For Selective Cold Gas Applications

Sil Brazed Ends

Part Number	SBT Valve size Inches	Valve Size mm	Ends	Weight Lbs.	Weight Kgs.	Estimated Cv
B-206BLL-12S6	1½"	40 mm	Silver Braze	7 Lbs.	3.2 Kgs.	29.00

Bronze Globe Valve for Cryogenic Service Goddard 202X Series Including 206LL, 206GF, 206ULL

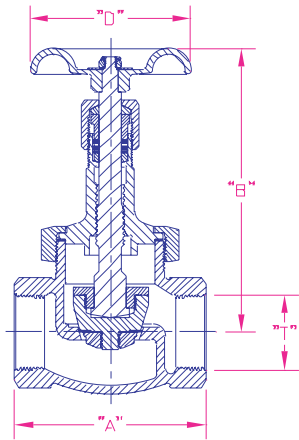

202 Series

202X

Pressure Rating 400 PSIG
Temperature Rating +150°F to -325°F
Non-Extended Valve for Cold Gas Applications
Conical Seat

Dimensional data
All Dimensional Data are in inches.

THREADED ENDS

Size	"A"	"B"	"D"	"T" NPT
1½"	4¾"	8⅝"	4"	1½"
2"	5¾"	9½"	4¾"	2"

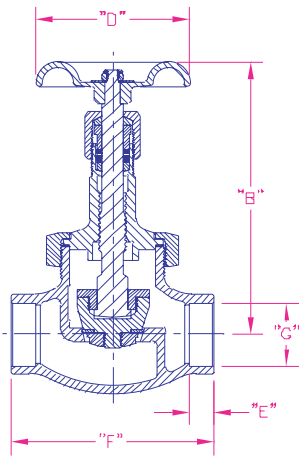

SILVER BRAZED ENDS

Size	"B"	"D"	"E"	"F"	"G"
½"	4⅝"	2"	.38	¾"	.628/.630
1"	4⅝"	2"	.44	1¼"	1.129/1.131
1½"	5"	2⅜"	.62	5¼"	1.629/1.632
2"	5¾"	2¾"	.66	6½"	2.129/2.132

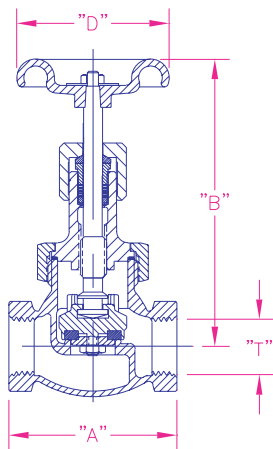

206GF

Pressure Rating 600 PSIG
Temperature Rating +350°F to -325°F
Non-Extended Stem - GRAFOIL® Packing, Gasket and PFA Seat
Dimensional data
All Dimensional Data are in inches.

THREADED ENDS

Size	"A"	"B"	"D"	"T" NPT
¼"	2⅝"	4⅝"	2"	¼"
½"	2⅝"	5"	2⅜"	½"
¾"	3 ⅜ ₁₆ "	5¾"	2¾"	¾"
1"	3¾"	6¾"	3"	1"
1½"	4¾"	8⅝"	4"	1½"
2"	5¾"	9½"	4¾"	2"

Bronze Globe Valve for Cryogenic Service Goddard 202X Series Including 206LL, 206GF, 206ULL

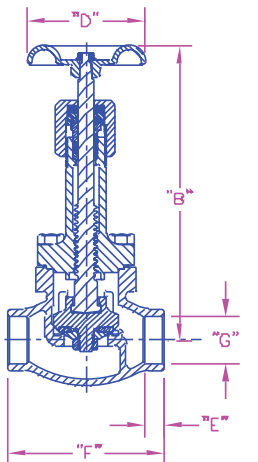
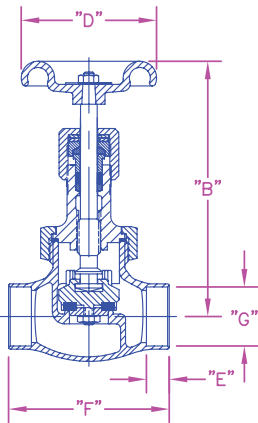
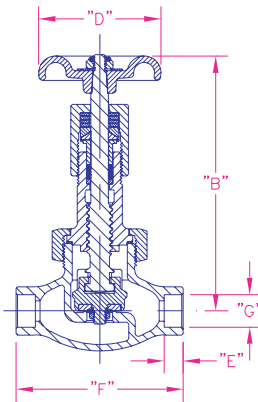
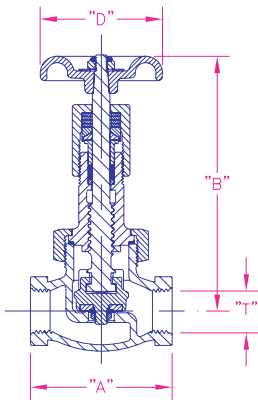

206LL

Pressure Rating 600 PSIG
Temperature Rating +150° F to -325° F
Live Load Packing

Dimensional Data
All Dimensions are in Inches

THREADED ENDS

Size	"A"	"B"	"D"	"T" NPT
1/4"	2 ⁵ / ₈ "	5"	2 ³ / ₈ "	1/4"
3/8"	2 ⁵ / ₈ "	5"	2 ³ / ₈ "	3/8"
1/2"	2 ⁵ / ₈ "	5"	2 ³ / ₈ "	1/2"
3/4"	3 ³ / ₁₆ "	5 ³ / ₄ "	2 ³ / ₄ "	3/4"
1"	3 ³ / ₄ "	5 ³ / ₄ "	3"	1"

SIL BRAZED ENDS

Size	"B"	"D"	"G"	"E"	"F"
1/4"	5"	2 ³ / ₈ "	.378/.380	.26	2 ³ / ₈ "
1/2"	5"	2 ³ / ₈ "	.628/.630	.38	3 ¹ / ₄ "
3/4"	5 ³ / ₄ "	2 ³ / ₄ "	.878/.880	.41	4 ¹ / ₄ "

206ULL

Pressure Rating 600 PSIG
Temperature Rating +150° F to -325° F
Live Load Packing - Union Bonnet

Dimensional Data
All Dimensions are in Inches

THREADED ENDS

Size	"A"	"B"	"D"	"T" NPT
1 1/2"	4 ³ / ₄ "	8 ⁵ / ₈ "	4"	1 1/2"
2"	5 ³ / ₄ "	11 ³ / ₄ "	4 ³ / ₄ "	2"

206BLL

Pressure Rating 600 PSIG
Temperature Rating +150° F to -325° F
Live Load Packing - Bolted Bonnet

Dimensional Data
All Dimensions are in Inches

SIL BRAZED ENDS

Size	"B"	"D"	"G"	"E"	"F"
1 1/2"	8 ⁵ / ₈ "	4"	1.625/1.638	.63	5 ¹ / ₄ "

Bronze Globe Valve for Cryogenic Service Goddard 222 Series Including 226LL, 226GF, 226ULL

Features

- **Top Entry:** This union bonnet valve can be permanently installed in the line and serviced from the top. Stainless Steel tube prevents stem distortion. Also available in bolted bonnet configuration.
- **Construction:** Bronze cast body and bonnet
Rugged construction for long life
- **Designed with the unique Kold-Seal™** and high CV. standard PTFE seat design assures bubble tight seating and high cycle life
- **Sizes:** ¼" through 3" (8mm through 80mm)
- **Ends:** Threaded (FNPT), Sil Braze Tube (SBT), Silver Braze Pipe, back brazed threaded pipe nipples
- **Service:** Liquified and vaporized atmospheric gases, LNG
- **Temperature Rating:** -325°F to 150°F (-196°C to +65°C)
- **Pressure Rating:** (Cold, Non-shock)
400 and 600 PSIG
Sizes 1½" to 3" PED approved per EN10204, 3.1
- **Kold-Seal™ Technology** assures tight seal preventing cryogen gas loss.
- **Extended stem** suitable for cold box, transport vehicles, pipelines, and customer service applications.
- **Live loaded option** improves life of asset and minimizes service costs.
- **Replaceable top works** means low maintenance costs.



Ordering Information

222X

Bronze Globe Valves, Extended Stem - Conical Seat, 400 PSIG Cold Working Pressure

Threaded End

Part Number	NPT size Inches	NPT Size mm	Ends	Weight Lbs.	Weight Kgs.	Estimated Cv
B-00222X-2T4	¼"	8 mm	Threaded	1.50 Lbs.	0.70 Kgs.	1.30
B-00222X-4T4	½"	15 mm	Threaded	1.50 Lbs.	0.70 Kgs.	3.25
B-00222X-6T4	¾"	20 mm	Threaded	3.00 Lbs.	1.40 Kgs.	6.25
B-00222X-8T4	1"	25 mm	Threaded	4.00 Lbs.	1.80 Kgs.	10.00
B-00222X-12T4	1½"	40 mm	Threaded	7.75 Lbs.	3.50 Kgs.	26.00
B-00222X-16T4	2"	50 mm	Threaded	12.50 Lbs.	5.70 Kgs.	45.00
B-00222X-20T4	2½"	63.5 mm	Threaded	61.00 Lbs.	27.70 Kgs.	50.00
B-00222X-24T4	3"	80 mm	Threaded	61.00 Lbs.	27.70 Kgs.	100.00

Bronze Globe Valve for Cryogenic Service Goddard 222 Series Including 226LL, 226GF, 226ULL

Sil Brazed End

Part Number	SBT size Inches	SBT Size mm	Ends	Weight Lbs.	Weight Kgs.	Estimated Cv
B-00222X-4S4	½"	15 mm	Silver Braze	2.00 Lbs.	0.90 Kgs.	3.25
B-00222X-6S4	¾"	20 mm	Silver Braze	2.75 Lbs.	1.30 Kgs.	6.25
B-00222X-8S4	1"	25 mm	Silver Braze	3.75 Lbs.	1.70 Kgs.	10.00
B-00222X-12S4	1½"	40 mm	Silver Braze	7.25 Lbs.	3.30 Kgs.	26.00
B-00222X-16S4	2"	50 mm	Silver Braze	11.50 Lbs.	5.20 Kgs.	45.00
B-00222X-24S4	3"	80 mm	Silver Braze	58.00 Lbs.	26.40 Kgs.	100.00

226LL

Bronze Globe Valves, Live Load Packing, Extended Stem, 600 PSIG Cold Working Pressure

Threaded End

Part Number	NPT size Inches	NPT Size mm	Ends	Weight Lbs.	Weight Kgs.	Estimated Cv
B-0226LL-2T6	¼"	8 mm	Threaded	1.50 Lbs.	0.70 Kgs.	1.30
B-0226LL-3T6	⅜"	10 mm	Threaded	1.50 Lbs.	0.70 Kgs.	2.40
B-0226LL-4T6	½"	15 mm	Threaded	1.50 Lbs.	0.70 Kgs.	3.25
B-0226LL-6T6	¾"	20 mm	Threaded	3.00 Lbs.	1.40 Kgs.	6.25
B-0226LL-8T6	1"	25 mm	Threaded	4.00 Lbs.	1.80 Kgs.	10.00

Sil Brazed Ends

Part Number	SBT size Inches	SBT Size mm	Ends	Weight Lbs.	Weight Kgs.	Estimated Cv
B-0226LL-4S6	½"	15 mm	Silver Braze	2.00 Lbs.	0.90 Kgs.	3.25
B-0226LL-6S6	¾"	20 mm	Silver Braze	2.75 Lbs.	1.30 Kgs.	6.25
B-0226LL-8S6	1"	25 mm	Silver Braze	3.75 Lbs.	1.70 Kgs.	10.00

226ULL

Bronze Globe Valves, Live Loaded Packing - Union Bonnet, Extended Stem, 600 PSIG Cold Working Pressure

Threaded End

Part Number	NPT size Inches	NPT Size mm	Ends	Weight Lbs.	Weight Kgs.	Estimated Cv
B-226ULL-12T6	1½"	40 mm	Threaded	7.75 Lbs.	3.50 Kgs.	26.00
B-226ULL-16T6	2"	50 mm	Threaded	12.50 Lbs.	5.70 Kgs.	45.00

Sil Brazed Ends

Part Number	SBT size Inches*	SBT Size mm*	Ends	Weight Lbs.	Weight Kgs.	Estimated Cv
B-226ULL-12S6	1½"	40 mm	Silver Braze	7.25 Lbs.	3.30 Kgs.	26.00
B-226ULL-16S6	2"	50 mm	Silver Braze	11.50 Lbs.	5.20 Kgs.	45.00

*Nominal Size

226XGF

Bronze Globe Valves, Extended Stem - Conical Seat Grafoil® Packing, Gasket and PFA Seat
600 PSIG Cold Working Pressure

Threaded End

Part Number	NPT size Inches	NPT Size mm	Ends	Weight Lbs.	Weight Kgs.	Estimated Cv
VB-226XGF-4T6	½"	15 mm	Threaded	1.50 Lbs.	0.70 Kgs.	3.25
VB-226XGF-6T6	¾"	20 mm	Threaded	3.00 Lbs.	1.40 Kgs.	6.25
VB-226XGF-8T6	1"	25 mm	Threaded	4.00 Lbs.	1.80 Kgs.	10.00
VB-226XGF-12T6	1½"	40 mm	Threaded	7.75 lbs.	3.5 Kgs.	26.00

226BLL

Bronze Globe Valves, Live Loaded Packing - Bolted Bonnet, Extended Stem, 600 PSIG Cold Working Pressure

Threaded End

Part Number	NPT size Inches	NPT Size mm	Ends	Weight Lbs.	Weight Kgs.	Estimated Cv
B-226BLL-12T6	1½"	40 mm	Threaded	7.75 Lbs.	3.50 Kgs.	26.00
B-226BLL-16T6	2"	50 mm	Threaded	12.50 Lbs.	5.70 Kgs.	45.00

Bronze Globe Valve for Cryogenic Service Goddard 222 Series Including 226LL, 226GF, 226ULL

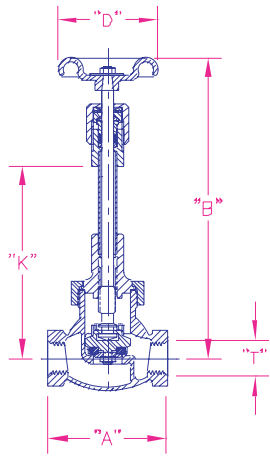

226ULL

Pressure Rating 600 PSIG
Temperature Rating +150°F to -325°F

Dimensional data
All Dimensional Data are in inches.

THREADED ENDS

Size	"A"	"B"	"D"	"T" NPT	"K"
1½"	4¾"	14⅝"	4"	1½"	9⅛"
2"	5¾"	15⅝"	4¾"	2"	9⅛"

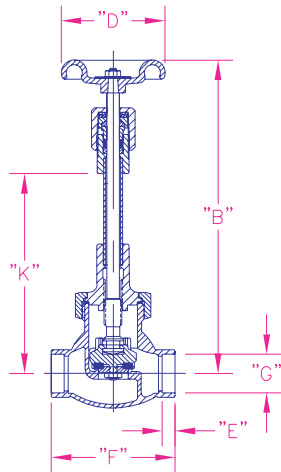

SIL BRAZED END

Size	"B"	"D"	"E"	"F"	"G"	"K"
1½"	14⅝"	4"	⅝"	5¼"	1.63"	9⅛"
2"	15⅝"	4¾"	21/32"	6½"	2.13"	9⅛"

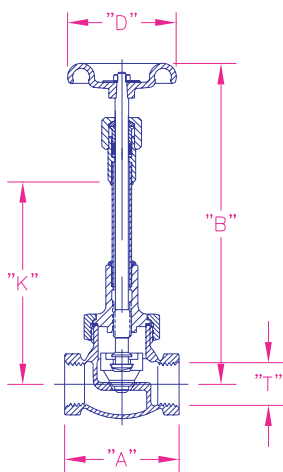

226XGF

Pressure Rating 600 PSIG
Temperature Rating +150°F to -325°F

Dimensional data
All Dimensional Data are in inches.

THREADED ENDS

Size	"A"	"B"	"D"	"T" NPT	"K"
½"	2⅝"	8¼"	2⅜"	½"	4⅞"
¾"	3 ⅜"	8⅝"	2¾"	¾"	4 13/16"
1"	3¾"	10½"	3"	1"	6½"

Bronze Globe Valve for Cryogenic Service Goddard 222 Series Including 226LL, 226GF, 226ULL

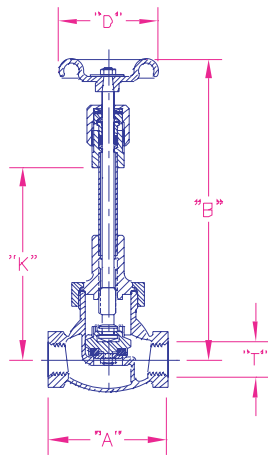

226LL

Pressure Rating 600 PSIG
Temperature Rating +150° F to -325° F

Dimensional Data
All Dimensions are in Inches

THREADED ENDS

Size	"A"	"B"	"D"	"T" NPT	"K"
1/4"	2 5/16"	7 9/16"	2"	1/4"	4 19/32"
3/8"	2 5/16"	7 9/16"	2"	3/8"	4 19/16"
1/2"	2 5/8"	8 1/4"	2 3/8"	1/2"	4 7/8"
3/4"	3 3/16"	8 5/8"	2 3/4"	3/4"	4 13/16"
1"	3 3/4"	10 1/2"	3"	1"	6 1/2"

*Bolted Bonnet

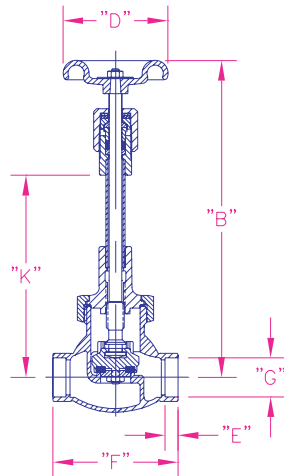

SIL BRAZED ENDS

Size	"B"	"D"	"E"	"F"	"G"	"K"
1/2"	8 1/4"	2 3/8"	3/8"	3 1/4"	.63	4 7/8"
3/4"	8 5/8"	2 3/4"	13/32"	3 3/4"	.88	4 13/16"
1"	10 1/2"	3"	7/16"	4 1/4"	1.13	6 1/2"

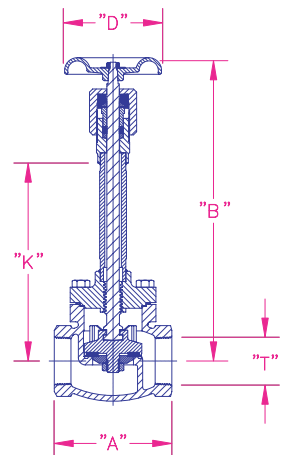

THREADED ENDS - BOLTED BONNET

Size	"A"	"B"	"D"	"T" NPT	"K"
1 1/2"	4 3/4"	14 5/8"	4"	1 1/2"	9 11/16"
2"	5 3/4"	14 15/16"	4 3/4"	2"	9 11/16"

Stainless Steel Swing Check Valve for Cryogenic Service Goddard 886 Series

Features

- **Top Entry:** This bolted bonnet valve can be permanently installed in the line and services from the top
- **Construction:** Designed to prevent back flow in cryogenic systems. Higher fluid capacity (CV) than poppet or lift check valves. 316L stainless steel investment cast body, cap and arm
- **Sizes:** ½" through 4" (15mm through 100mm)
- **Ends:** Socket weld and butt weld schedule 10 and 40
- **Temperature Rating:** -325°F to 150°F (-196°C to +66°C)
- **Pressure Rating:** (Cold, Non-shock)
400 PSIG (27 Bar) ½" - 2"
275 PSIG (19 Bar) 150# ANSI Class 3" and 4"
720 PSIG (50 Bar) 300# ANSI Class 3" and 4"
PED Approved, Approved for US and Canada
- **Note: Do not use for reciprocating gas service.**
- **Our investment cast stainless steel is specified by leading industrial gas companies for storage tank and yard operations.**
- **Ideal for liquid atmospheric gases and LNG storage and handling.**
- **High cycle life and superior sealing.**
- **Valves for hydrogen service can be supplied.**
(-425°F to +350°F)



Ordering Information

886

Stainless Steel Swing Check Valves
Soft Seat

GRAFOIL® Gasket - Hydrogen Service - Socket Weld

Part Number	Valve Size		End Connection	Seat	Pressure Rating	Estimated CV	Weight Lbs.
	Inches	mm					
S-0886GF-4S	½"	15 mm	Socket Weld	Soft	400 (26 Bar)	4.50	3 Lbs.
S-0886GF-6S	¾"	20 mm		Soft	400 (26 Bar)	12.00	6 Lbs.
S-0886GF-8S	1"	25 mm		Soft	400 (26 Bar)	61.00	11 Lbs.
S-0886GF-12S	1½"	40 mm		Soft	400 (26 Bar)	99.00	17 Lbs.

PTFE Gasket - Socket Weld

Part Number	Valve Size		End Connection	Seat	Pressure Rating	Estimated CV	Weight Lbs.
	Inches	mm					
S-000886-4S	½"	15 mm	Socket Weld	Soft	400 (26 Bar)	4.50	3 Lbs.
S-000886-6S	¾"	20 mm		Soft	400 (26 Bar)	12.00	6 Lbs.
S-000886-8S	1"	25 mm		Soft	400 (26 Bar)	61.00	11 Lbs.
S-000886-12S	1½"	40 mm		Soft	400 (26 Bar)	99.00	17 Lbs.

Stainless Steel Swing Check Valve for Cryogenic Service Goddard 886 Series

PTFE Gasket - Butt Weld

Part Number	Valve Size		End Connection	Seat	Butt Weld Schedule	Pressure Rating	Estimated CV	Weight Lbs.
	Inches	mm						
S-000886-4WA	1/2"	15 mm	Butt Weld	Soft	10	400 (26 Bar)	4.50	3 Lbs.
S-000886-8WA	1"	25 mm			10	400 (26 Bar)	18.00	11 Lbs.
S-000886-12WA	1 1/2"	40 mm			10	400 (26 Bar)	61.00	17 Lbs.
S-000886-16W3A	2"	50 mm			10	720 (50 Bar)	99.00	17 Lbs.
S-000886-24WA	3"	80 mm			10	275 (19 Bar)	255.00	47 Lbs.
S-000886-24WJ	3"	80 mm			40	275 (19 Bar)	225.00	46 Lbs.
S-000886-32W3J	4"	100 mm			40	720 (50 Bar)	475.00	95 Lbs.
S-000886-32WA	4"	100 mm			10	275 (19 Bar)	475.00	95 Lbs.

886M

Stainless Steel Swing Check Valves - Metal Seat

GRAFOIL® Gasket - Hydrogen Service

Part Number	Valve Size		End Connection	Seat	Pressure Rating	Estimated CV	Weight Lbs.
	Inches	mm					
S-00886M-4S3	1/2"	15 mm	Socket Weld	Metal	720 (50 Bar)	4.50	3 Lbs.
S-00886M-8S3	1"	25 mm			720 (50 Bar)	18.00	11 Lbs.
S-00886M-12S3	1 1/2"	40 mm			720 (50 Bar)	61.00	17 Lbs.

Butt Weld Ends

Part Number	Valve Size		End Connection	Seat	Butt Weld Schedule	Pressure Rating	Estimated CV	Weight Lbs.
	Inches	mm						
S-0886M-16W3A	2"	50 mm	Butt Weld	Metal	10	720 (50 Bar)	99.00	17 Lbs.
S-00886M-24W3J	3"	80 mm			40	720 (50 Bar)	225.00	46 Lbs.
S-00886M-24W3A	3"	80 mm			10	720 (50 Bar)	225.00	46 Lbs.
S-00886M-32WA	4"	100 mm			10	275 (19 Bar)	475.00	95 Lbs.
S-00886M-32W3J	4"	100 mm			40	720 (50 Bar)	475.00	95 Lbs.

Butt Weld Ends with GRAFOIL® Gasket for Hydrogen Service

Part Number	Valve Size		End Connection	Seat	Butt Weld Schedule	Pressure Rating	Estimated CV	Weight Lbs.
	Inches	mm						
S-886MGF-16W3A	2"	50 mm	Butt Weld	Metal	10	720 (50 Bar)	99.00	17 Lbs.
S-886MGF-24W3A	3"	80 mm	Butt Weld		10	720 (50 Bar)	225.00	46 Lbs.

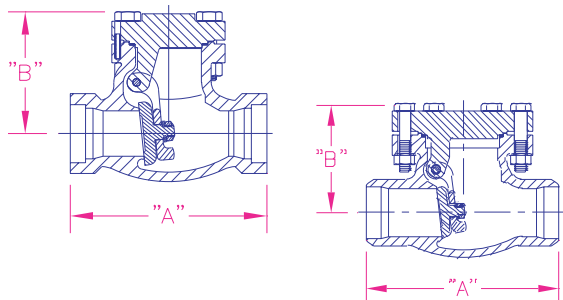

886

Pressure Rating 300 PSIG Non-Shock Cold, Temperature Rating +150° F to - 325° F
All Dimensional Data are in inches.

Size	"A"	"B"
1/2"	4 1/4"	2 1/2"
3/4"	5"	3 1/4"
1"	5"	3 1/4"
1 1/2"	6 1/2"	4"
2"	8"	4 1/2"

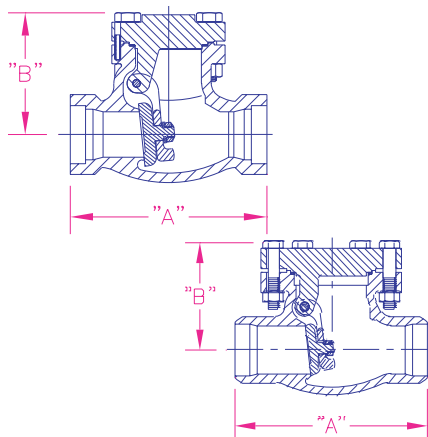

886M

Service 300 Class 720 PSI Non-Shock Cold, Temperature Rating +150° F to - 325° F
All Dimensional Data are in inches.

Size	"A"	"B"	Butt Weld End Schedule
1 1/2"	6 1/2"	4"	10
2"	8"	4 1/2"	10
3"	9 1/2"	5 3/4"	10 & 40
4"	11 1/2"	8 3/8"	10
4"	14"	8 3/8"	40

Size	"A"	"B"	End	End Dimension
1/2"	2 7/16"	4 1/4"	Socket Weld	SCH 10
1/2"	2 7/16"	4 1/4"		1/2" Pipe Socket

Bronze Swing Check Valve for Cryogenic Service Including 846M Goddard 840 Series

Features

- **Top Entry:** This union bonnet valve can be permanently installed in the line and services from the top
- **Construction:** Designed to prevent back flow in cryogenic systems. Higher fluid capacity (CV) than poppet or lift check valves. Bronze body and internals. Rugged construction for long life and minimal down time
- **Sizes:** ½" through 2" (15mm through 50mm)
- **Ends:** Threaded (FNPT), or with Sil Brazed Tube (SBT)
SCH-10, Threaded back brazed pipe nipples in 1" increments up to 6"
SCH-40, Threaded back brazed pipe nipples in 1" increments up to 6"
SCH-80, Threaded back brazed pipe nipples in 1" increments up to 6"
- **Temperature Rating:** -325°F to +150°F (-196°C to +65°C)
- **Pressure Rating:** (Cold, Non-shock)
840 Series 400 PSIG
846M Series 600 PSIG
Sizes 1½" to 2" PED Approved Per EN10204 3.1

Note: Do not use for reciprocating gas service.



Ordering Information

840

Bronze Swing Check Valves - Soft Seated, Threaded, Sil Brazed Ends, Back Brazed Pipe Nipples
400 PSIG Cold Working Pressure

Threaded Ends

Part Number	NPT Size Inches	NPT Size mm	Ends	Weight Lbs.	Weight Kgs.	Estimated CV
B-000840-4T	½"	15 mm	Threaded	2.00 Lbs.	0.91 Kgs.	4.50
B-000840-6T	¾"	20 mm	Threaded	4.00 Lbs.	1.81 Kgs.	7.00
B-000840-8T	1"	25 mm	Threaded	4.50 Lbs.	2.04 Kgs.	10.00
B-000840-12T	1½"	40 mm	Threaded	8.50 Lbs.	3.86 Kgs.	40.00
B-000840-16T	2"	50 mm	Threaded	14.50 Lbs.	6.58 Kgs.	100.00

Silver Brazed - Pipe Nipple

Part Number	SBT Size Inches*	SBT Size mm*	Ends	Weight Lbs.	Weight Kgs.	Estimated CV
B-000840-4S	½"	15 mm	Silver Braze	2.50 Lbs.	1.13 Kgs.	4.50
B-000840-6S	¾"	20 mm	Silver Braze	4.5 Lbs.	2.05 Kgs.	7.00
B-000840-8S	1"	25 mm	Silver Braze	5.25 Lbs.	2.38 Kgs.	10.00
B-000840-12S	1½"	40 mm	Silver Braze	10.75 Lbs.	4.88 Kgs.	40.00
B-000840-16S	2"	50 mm	Silver Braze	17.50 Lbs.	7.94 Kgs.	100.00

* Nominal Size

846M

Bronze Swing Check Valves - Metal Seated, Threaded, Sil Brazed Ends, Back Brazed Pipe Nipples
600 PSIG Cold Working Pressure

Threaded Ends

Part Number	NPT Size Inches	NPT Size mm	Ends	Weight Lbs.	Weight Kgs.	Estimated CV
B-000846M-4T6	½"	15 mm	Threaded	2.00 Lbs.	0.91 Kgs.	4.50
B-000846M-8T6	1"	25 mm	Threaded	4.50 Lbs.	2.04 Kgs.	10.00
B-000846M-12T6	1½"	40 mm	Threaded	8.50 Lbs.	3.86 Kgs.	40.00
B-000846M-16T6	2"	50 mm	Threaded	14.50 Lbs.	6.58 Kgs.	100.00

Bronze Swing Check Valve for Cryogenic Service Including 846M Goddard 840 Series

Silver Brazed - Pipe Nipple

Part Number	SBT Size Inches*	SBT Size mm*	Ends	Weight Lbs.	Weight Kgs.	Estimated CV
B-000846M-4S6	1/2"	15 mm	Silver Braze	2.50 Lbs.	1.13 Kgs.	4.50
B-000846M-6S6	3/4"	20 mm	Silver Braze	4.50 Lbs.	2.04 Kgs.	7.00
B-000846M-8S6	1"	25 mm	Silver Braze	5.25 Lbs.	2.38 Kgs.	10.00
B-000846M-12S6	1 1/2"	40 mm	Silver Braze	10.75 Lbs.	4.88 Kgs.	40.00
B-000846M-16S6	2"	50 mm	Silver Braze	17.50 Lbs.	7.94 Kgs.	100.00

* Nominal Size

- Contact company for threaded, back brazed pipe nipple information

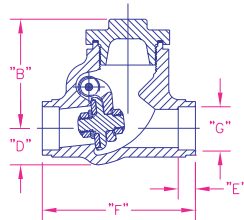
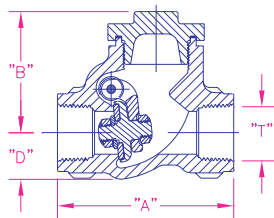

840 Series

Pressure Rating MSS SP-80 Class 200
MAWP 400 PSIG Non-Shock Cold
Temperature Rating +150°F to -325°F

Dimensional data
All Dimensional Data are in inches.

Size	"A"	"B"	"D"	"T" NPT	"E"	"F"	"G"
1/2"	3.00"	2.13"	3/4"	1/2"	.38"	2.94"	.63"
3/4"	3.69"	2.81"	1.12"	3/4"	.41"	3.60"	.88"
1"	4.00"	2.81"	1.13"	1"	.45"	4.00"	1.13"
1 1/2"	5.03"	3.63"	1.44"	1 1/2"	.63"	5.03"	1.63"
2"	6.35"	4.34"	1.84"	2"	.66"	6.35"	2.13"

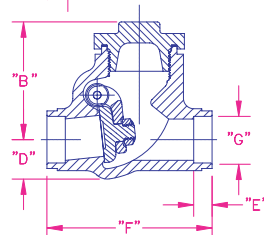
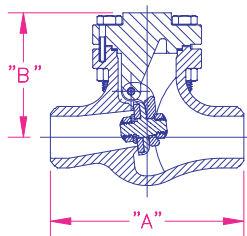

846M Series

Pressure Rating MSS SP-80 Class 300
MAWP 600 PSIG Non-Shock Cold
Temperature Rating +150°F to -325°F

Dimensional data
All Dimensional Data are in inches.

Size	"A"	"B"	"D"	"T" NPT	"E"	"F"	"G"
1/2"	3.00"	2.13"	3/4"	1/2"	.38"	2.94"	.63"
3/4"	3.69"	2.81"	1 1/8"	3/4"	.41"	3.60"	.88"
1"	4.00"	2.81"	1 1/8"	1"	.45"	4.00"	1.13"
1 1/2"	5.03"	3.63"	1 7/16"	1 1/2"	.63"	5.03"	1.63"
2"	6.35"	4.34"	1 27/32"	2"	.66"	6.35"	2.13"

Goddard Quikconnect Vacuum Couplings

Features

- Goddard "Quikconnect" vacuum couplings are available in either brass or 304 stainless steel
- An extensive range of tube sizes available. Most sizes nest, and can be used as reducers in combination with one another.
- May be used for vacuum down to 1×10^{-8} Microns
- Viton O-rings are standard
- "Quikconnect" vacuum couplings have four basic components:
 - * Knurled Nut
 - * Retainer Ring
 - * O-ring
 - * Sleeve

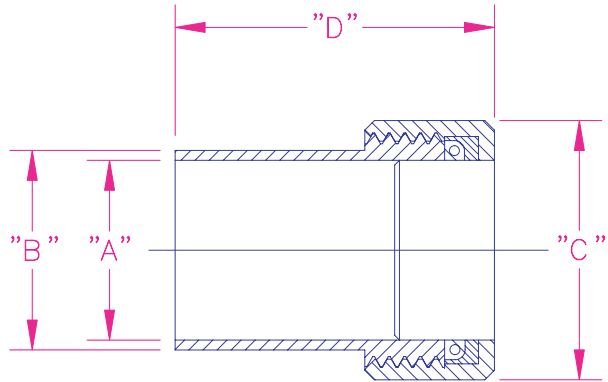

Ordering Information

Quikconnect Vacuum Couplings

Brass Machine Finish	304-Stainless Machine Finish	"A"	"B"	"C"	"D"	Tube OD Size
B-000006-M	S-000006-M	0.720"	0.375"	5/8"	1 1/32"	1/16"
B-000012-M	S-000012-M	0.135"	0.375"	5/8"	1 1/32"	1/8"
B-000018-M	S-000018-M	0.197"	0.375"	5/8"	1 1/32"	3/16"
B-000025-M	S-000025-M	0.260"	0.375"	5/8"	1 1/32"	1/4"
B-000031-M	S-000031-M	0.322"	0.500"	13/16"	1 1/4"	5/16"
B-000038-M	S-000038-M	0.385"	0.500"	13/16"	1 1/4"	3/8"
B-000050-M	S-000050-M	0.510"	0.625"	7/8"	1 1/4"	1/2"
B-000062-M	S-000062-M	0.635"	0.750"	1 1/8"	1 3/8"	5/8"
B-000075-M	S-000075-M	0.760"	0.875"	1 1/4"	1 1/2"	3/4"
B-000087-M	S-000087-M	0.885"	1.000"	1 7/16"	1 23/32"	1/2"
B-000100-M	S-000100-M	1.010"	1.125"	1 1/2"	1 13/16"	1"
B-000112-M	S-000112-M	1.135"	1.250"	1 5/8"	1 15/16"	1 1/8"
B-000125-M	S-000125-M	1.260"	1.500"	2"	1 3/16"	1 1/4"
B-000138-M	S-000138-M	1.385"	1.625"	2"	1 3/16"	1 3/8"
B-000150-M	S-000150-M	1.150"	1.750"	2 1/4"	1 3/16"	1 1/2"
B-000162-M	S-000162-M	1.635"	1.875"	2 3/8"	2 1/4"	1 5/8"
B-000200-M	S-000200-M	2.010"	2.250"	2 3/4"	2 31/32"	2"

Limited Warranty and Limitation of Liability



LIMITED WARRANTY

RegO warrants products and repair kits manufactured by it to be free from defects in materials and workmanship under normal use and service for a period of 12 months from the date of installation or operation or 18 months from the date of shipment from the factory, whichever is earlier. If within thirty days after buyer's discovery of what buyer believes is a defect, buyer notifies RegO thereof in writing, RegO, at its option, and within forty-five days, will repair, replace F.O.B. point of manufacture, or refund the purchase price of that part or product found by it to be defective. Failure of buyer to give such written notice within thirty days shall be deemed an absolute and unconditional waiver of any and all claims of buyer arising out of such defect.

This warranty does not extend to any product or part that is not installed and used in accordance with RegO's printed instructions, all applicable state and local regulations, and all applicable national standards, such as those promulgated by NFPA, DOT, CGA, and ANSI. This warranty does not extend to any product or part that has been damaged by accident, misuse, abuse or neglect, nor does it extend to any product or part which has been modified, altered, or repaired in the field.

Except as expressly set forth above, and subject to the limitation of liability below, RegO makes NO OTHER WARRANTY, EXPRESS OR IMPLIED, INCLUDING, BUT NOT LIMITED TO THE IMPLIED WARRANTIES OF MERCHANTABILITY AND FITNESS FOR A PARTICULAR PURPOSE, with respect to its products and parts, whether used alone or in combination with others. RegO disclaims all warranties not stated herein.

LIMITATION OF LIABILITY

RegO's total liability for any and all losses and damages arising out of any cause whatsoever shall in no event exceed the purchase price of the products or parts in respect of which such cause arises, whether such cause be based on theories of contract, negligence, strict liability, tort or otherwise.

RegO shall not be liable for incidental, consequential or punitive damages or other losses. RegO shall not be liable for, and buyer assumes liability for, all personal injury and property damage connected with the handling, transportation, possession, further manufacture, other use or resale of products, whether used alone or in combination with any other products or material.

EUROPEAN PED CERTIFICATION			
The following product categories have received PED certification by the notified body Lloyd's Registry of Shipping #0038			
Valve number	Maximum Connection Size	DN	PED Category
9560 series	1"	25	SEP
9500 series	1"	25	SEP
BK8400 series	2"	50	II
BK9400 series	2"	50	II
T9450 series	½"	15	TPED
T9460 series	½"	15	TPED
1682 series	¼"	8	SEP
BR-&1780 series	1"	25	SEP
RG series	¼"	8	SEP
ECL series	¼"	8	SEP
PRV9430 & PRV19430 series	½"	15	IV
SS9430 & PRV29430 series	½"	15	IV

If RegO furnishes technical advice to buyer, whether or not at buyer's request, with respect to application, further manufacture or other use of the products and parts, RegO shall not be liable for technical advice and buyer assumes all risks of such advice and the results thereof.

NOTE: Some states do not allow the limitation or exclusion of incidental or consequential damages, so the above limitations or exclusions, wholly or partially, may not apply. The portions of this limited warranty and limitation of liability shall be considered severable and all portions which are not disallowed by applicable law shall remain in full force and effect.

WARNING

All RegO products are mechanical devices that will eventually become inoperative due to wear, corrosion and aging of components made of materials such as rubber, etc. The environment and conditions of use will determine the safe service life of these products. Periodic inspection and maintenance are essential to avoid serious injury and property damage.

Many RegO products are manufactured components which are incorporated by others on or in other products or systems used for storage, transport, transfer and otherwise for use of toxic, flammable and dangerous liquids and gases. Such substances must be handled by experienced and trained personnel only, using accepted governmental and industrial safety procedures.

NOTICE TO USERS OF PRODUCTS

The Limited Warranty stated above is a factory warranty to the first purchasers of RegO products. Since most users have purchased these products from RegO distributors, the user must within thirty (30) days after the user's discovery of what user believes is a defect, notify in writing the distributor from whom he purchased the product/parts. The distributor may or may not at the distributor's option, choose to submit the product/parts to RegO pursuant to its Limited Warranty. Failure by buyer to give such written notice within thirty (30) days shall be deemed an absolute and unconditional waiver or buyer's claim for such defects. Acceptance of any alleged defective product/parts by RegO's distributor for replacement or repairs under the terms of RegO's Limited Warranty in no way obligates RegO to the terms of the above warranty.

Because of a policy of continuous product improvement, RegO reserves the right to change designs, materials or specifications without notice.

Canadian Registration Numbers
The majority of products in this catalog are registered with the Canadian Department of Labor under the following reference Number: 0* 7770.5** * Represents Fitting Categories: A, C, G, H ** Represents Province code number



Oxygen

Argon

CO₂

HELIUM

REGO®



Hydrogen

Oxygen

LINE

3181 Lear Drive Burlington, NC 27215 USA Phone (336) 226-3244 Fax (336) 227-6294

E-mail: CFLO@REGOPRODUCTS.COM Catalog CG-400A Printed in the U.S.A.

www.regocryoflow.com

NITROGEN

02-0905-0711